



Accurate · Fast · Robust · Versatile

# SIMPACK CRANK TRAIN

## Application

### What is SIMPACK?

SIMPACK is a general purpose multi-body simulation (MBS) software tool which is used to aid the development of any mechanical or mechatronic device, ranging from single components through to complete systems, e.g. vehicles, high performance Formula 1 engines, crank train, valve train, timing mechanism, chain and complete engine models. All SIMPACK products are 100% compatible.

SIMPACK Crank Train is an add-on module tailored to the specific requirements of the engine simulation sector.

### Applications:

- Simulation of any engine/crankshaft design
- Kinematic and dynamic simulation
- Geometric and material modification
- Eigenfrequency analysis
- Order analysis
- Optimization
- Durability / Fatigue analysis

### Highlights:

- Unlimited modeling flexibility
- Extreme non-linear system behavior, e.g. gas forces, EHD interface to IST Tower
- Fully parameterized highly detailed engine database for all typical engine types available
- Acoustic analyses in the frequency and time domain
- Scalable level of model detail and complexity
- Batch jobs
- Automatic analysis reports
- Interfaces to third party software

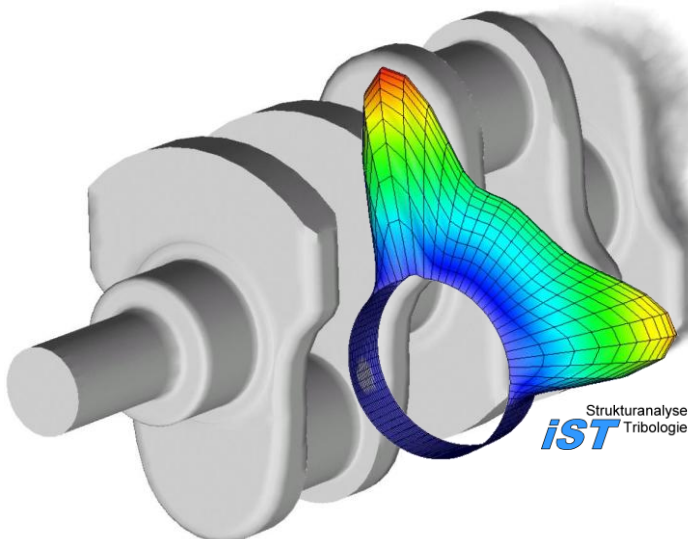
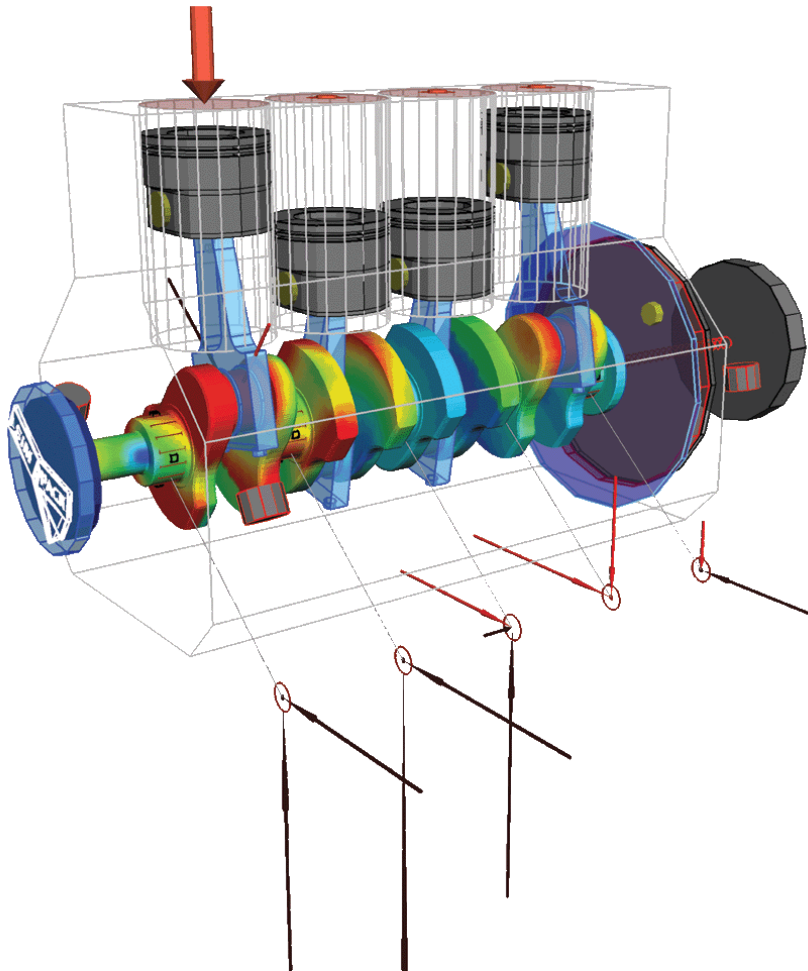

Strukturanalyse  
**IST**  
Tribologie

## Features:

- Elasto-Hydrodynamic Bearings, EHD – IST Tower software package
- Frequency and amplitude depended elements
- Flexible body generation within SIMPACK
- Importation of flexible bodies from FEM codes
- Easy implementation of user specific code
- Displacement animation in SIMPACK
- Stress animation in SIMPACK
- Continuous "Run Up"
- Step wise "Run Up"

## Interfaces to:

- CAD software
- Finite element codes
- Control software
- Fatigue analysis software
- Optimization tools

## Operating systems:

- Windows and Linux.  
See: [www.SIMPACK.com/platforms.html](http://www.SIMPACK.com/platforms.html)

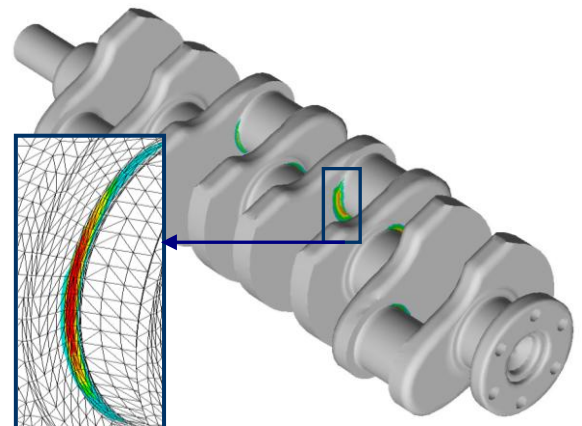
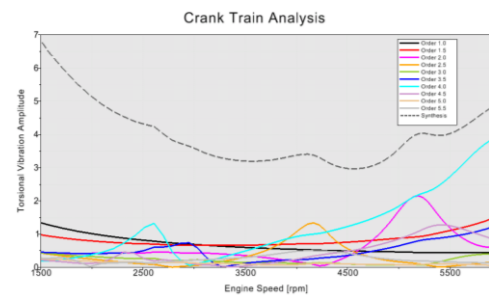
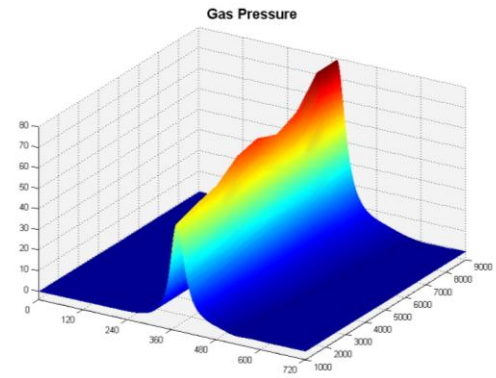

## SIMPACK Customer Solution Centers

### Germany

#### Worldwide Headquarters

SIMPACK AG  
Friedrichshafener Strasse 1  
82205 Gilching, Germany

Phone: +49 (0)8105 77266-0  
Fax: +49 (0)8105 77266-11  
sales@SIMPACK.de  
www.SIMPACK.com

### USA

SIMPACK US Inc.  
Robert Solomon  
25925 Telegraph Road, Suite 101  
Southfield Michigan 48033, USA

Phone: +1 248 996-8750  
Fax: +1 248 996-8930  
Mobile: +1 251 923 9566  
info@SIMPACK-US.com  
www.SIMPACK.com

### France

SIMPACK France S.A.S.  
Immeuble "Le President",  
4eme étage  
40, Avenue Georges Pompidou  
69003 Lyon, France

Phone : +33 (0)437 5619-71  
info@SIMPACK.fr  
www.SIMPACK.com

### Japan

SIMPACK Japan K.K.  
5F Okubo Bldg.  
2-4-12 Yotsuya  
Shinjuku-ku  
Tokyo 160-0004, Japan

Phone: +81 (0)3 5360-6631  
Fax: +81 (0)3 5360-6632  
info@SIMPACK.jp  
www.SIMPACK.jp

### Great Britain

SIMPACK UK Ltd.  
The Whittle Estate  
Cambridge Road  
Whetstone  
Leicester LE8 6LH, UK

Phone: +44 (0)116 27513-13  
Fax: +44 (0)116 27513-33  
Mobile: +44 (0)7767 416 656  
info@SIMPACK.co.uk  
www.SIMPACK.co.uk