

Hydraulic lash adjuster

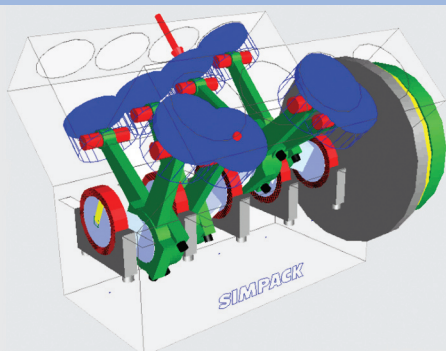

Crank train engine model

### SIMPACK ENGINE ON ITS WAY TO RELEASE

The first version of SIMPACK ENGINE will be released in the beginning of 2004. SIMPACK ENGINE contains many new features in order to simulate high end engine specific multi-body dynamics. The module focuses on detailed and highly sophisticated valve and crank train dynamic design and the optimisation of the 'upper' (valve train) and 'lower' (crank train) engine dynamics. SIMPACK ENGINE provides brand new modelling elements and methods such as:

- detailed hydraulic lash adjuster
- force element: Hertzian contact forces
- automatic creation of dynamic valve springs with different levels of detail
- flexible camshafts created directly in SIMPACK
- detailed geometrically and physically described gears with clearance
- 2D and 3D direct contact on flexible bodies (no contact surface bracing!)
- friction type bearings ((E)HD)
- gas forces

Detailed and efficient chain and belt solutions will be released in future versions of SIMPACK ENGINE in 2004. Based on the well known SIMPACK relative co-ordinate algorithm, together with new methods, SIMPACK ENGINE will offer excellent simulation times and accuracy.

SIMPACK ENGINE models are fully compatible with standard SIMPACK models. SIMPACK ENGINE's model set-up using the standard SIMPACK database, substructure and parameterisation techniques for modelling the valve train, crank train, accessory drive, timing mechanism, engine mounts and complete engine models will be easy to use, efficient and reliable.

### SIMPACK ELASTOMER

Currently INTEC is developing a new SIMPACK library for elastomer models, i.e. elements that show frequency and amplitude dependent elasticity and damping behaviour. During the next few months a number of important rubber and hydro bearing models, obtained from literature, will be implemented. The first model available will be based on an approach which excels at the low effort required for the determination of its parameters. The model was implemented with the help of its inventor, Mr. Pfeffer, currently employed at the University of Bath, and in co-operation with MAN Trucks.

This module will be available at the end of the year 2003.

### AUTOMOBILE AND RAILWAY VEHICLE DYNAMICS IN LYON

INTEC, along with the exhibition stand, were present at the congress „Dynamique Vehicule et Confort de Suspension Automobile et Ferroviaire“ on 3<sup>rd</sup> and 4<sup>th</sup> of June in Lyon. INTEC also presented a paper, which focussed on the recent developments in combined control systems and dynamic simulation in automotive and railway engineering, and gave an insight into SIMPACK's new technologies in the field of real-time simulation.