



An Investigation into the Effects of Rolling Element Bearing Flexibility in a Wind Turbine Planetary Gearbox

20th November 2007

Nawazish Ali Zaidi, Richard Dorling and Andy Poon
Romax Technology Limited, Nottingham, UK



- Planetary gear systems are most suitable for wind turbine application due to their large power transfer capacity.
- Robust performance in terms of power transfer capacity requires “Equal load sharing” among the planets.
- This can be achieved by allowing the sun to float and take up any variation in the meshing with the planets by the lateral movement of the sun.
- Equal load share can also be enhanced by making the planet pins flexible, or changing the stiffness of the planet bearings. This also allows any manufacturing errors to be absorbed.
- Flexibility in the mounting of the planets can also be used to reduce the impact of shock loads. However, when such flexibility is combined with floating elements, such as the sun and planet carrier, the vibration of the system as a whole can become an issue, especially the whirling motion of the floating elements.

Wind Turbine Gearbox

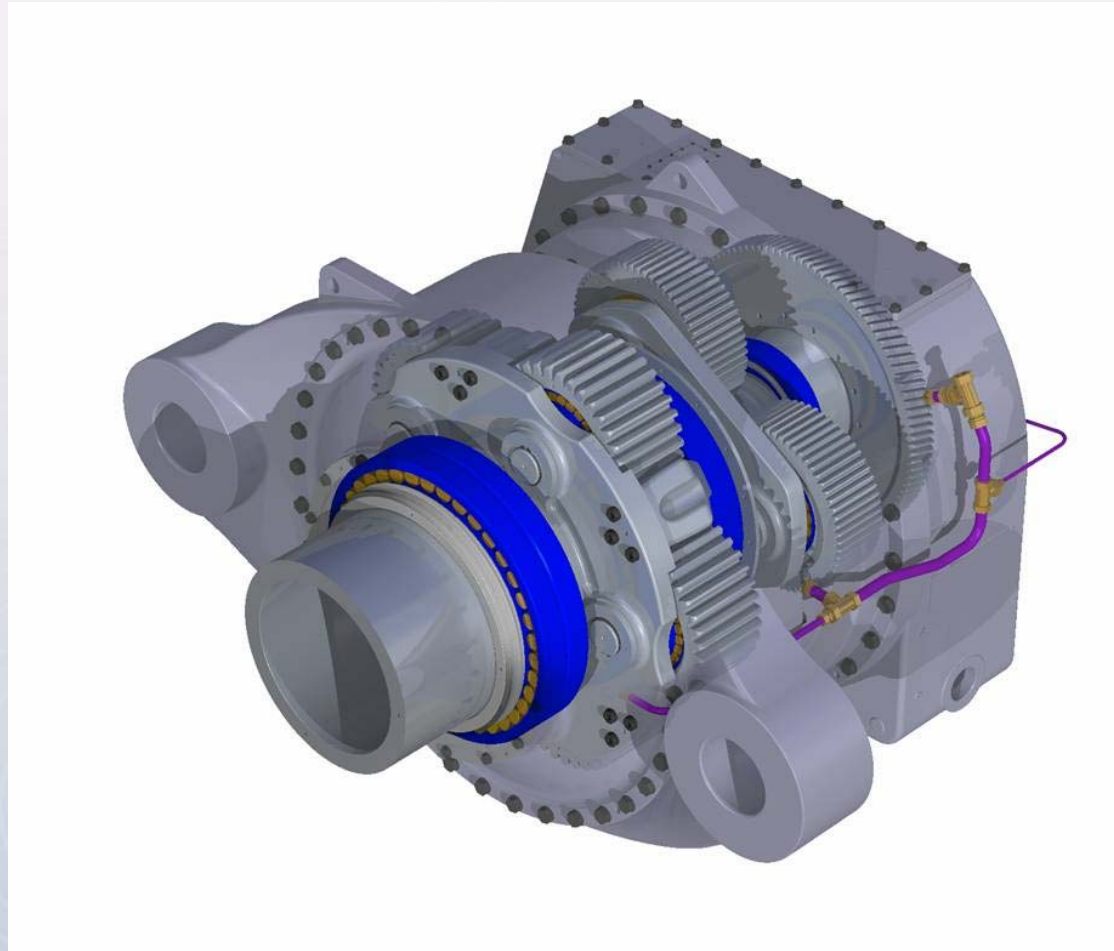

Transient loading in WT

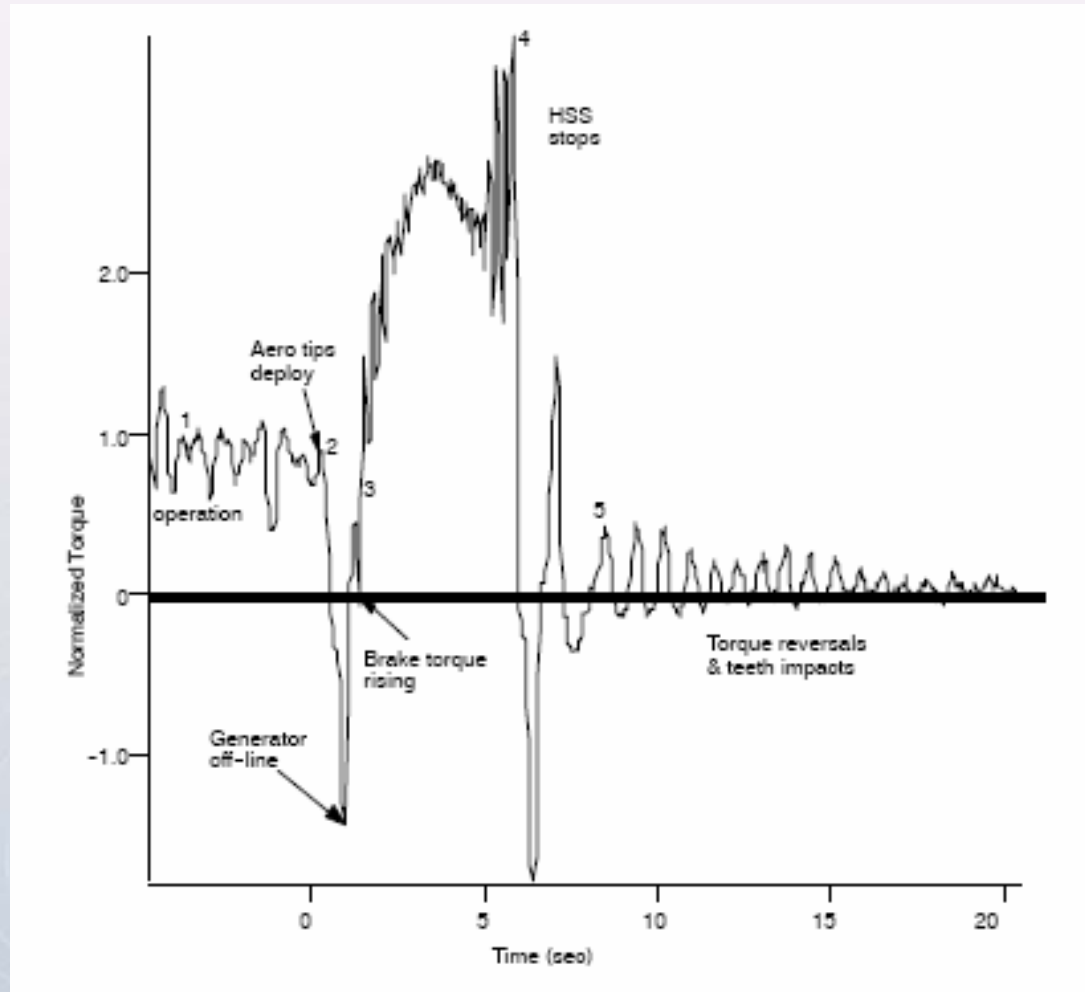

AGMA: Rotor shaft torque during braking event

- Conventionally, multi-body software will use either a linear model or a force-displacement curve for bearing.
- Romax's bearing model has advanced capabilities that use actual contacts of the bearing elements with the races to calculate forces for each simulation step.
- Each directions force/moment is coupled to displacements/tilts in all six directions which is not practical to do by a look-up table.
- By interfacing this full non-linear coupled bearing module with SIMPACK, the dynamic analysis ability and accuracy of SIMPACK is significantly enhanced.

X displacement versus X load

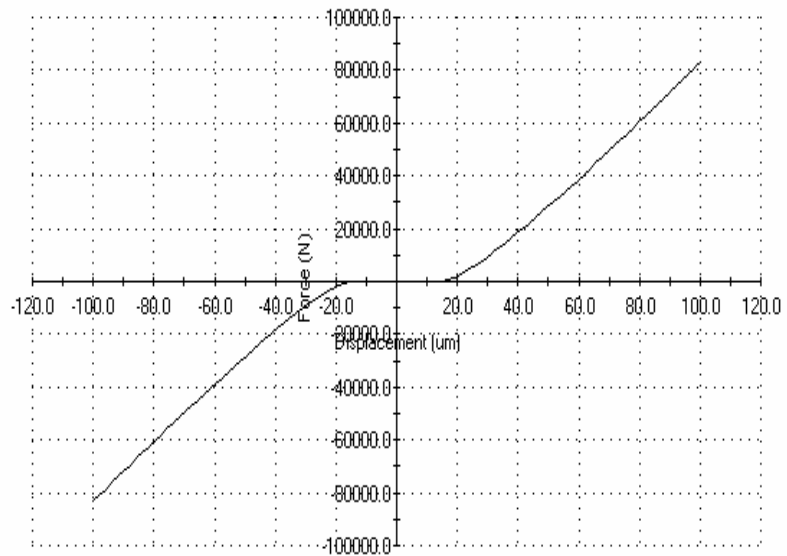

Displacement vs Load

X tilt versus X moment

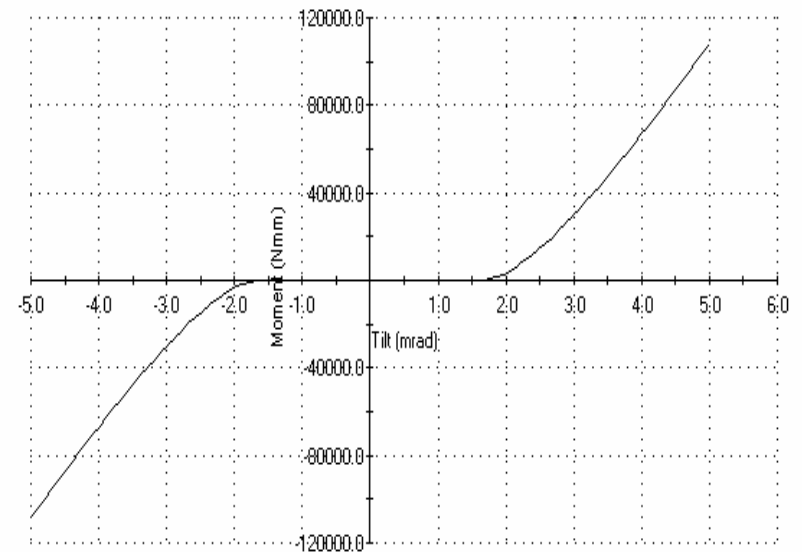

Tilt vs Moment

- The Romax bearing is implemented in Simpack by interfacing through user routines available in Simpack.
- A single bearing is selected within Simpack model from the Romax bearing database based on the following criterion
 - the manufacture catalogue name
 - Bearing diameter
 - Bore
 - Width
 - The mounting direction and preload on the bearing can also be defined.

Objectives of the analysis



- To confirm that the planet carrier and sun orbits are present in the dynamic simulation.
- To examine the effect of bearing stiffness on planet carrier and sun orbits
- To examine the requirement of non-linear bearing models as opposed to linear models
- To examine the dynamic response to shock loading.

- This paper examines a planetary system with floating sun and planet carrier, and flexible planet mounts.
- The system to be studied is a relatively simple system, but has complex behaviour of interest in the design of gearboxes (especially wind turbines).
- The system is a three planet epicyclic gear set. Flexible pins are used to support the planet wheels, and the planet carrier and sun wheel are allowed to float.
- The floating behaviour of the sun and planet carrier is achieved by using bearings with low tilt stiffness to support the planet carrier and sun shafts.

The System

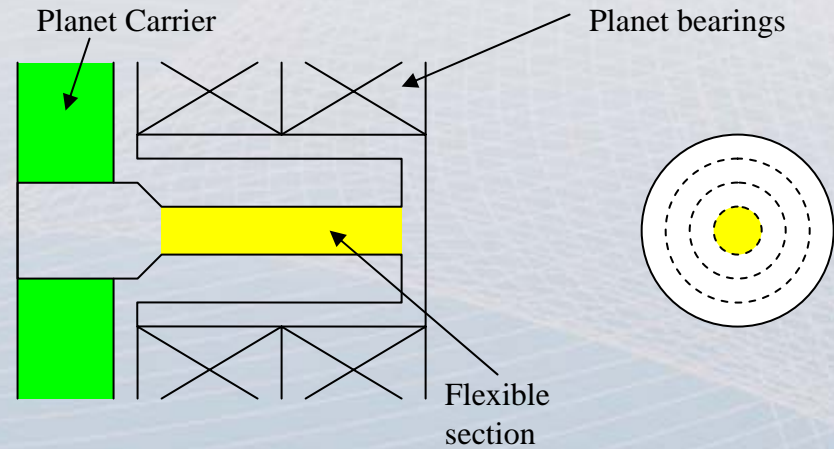
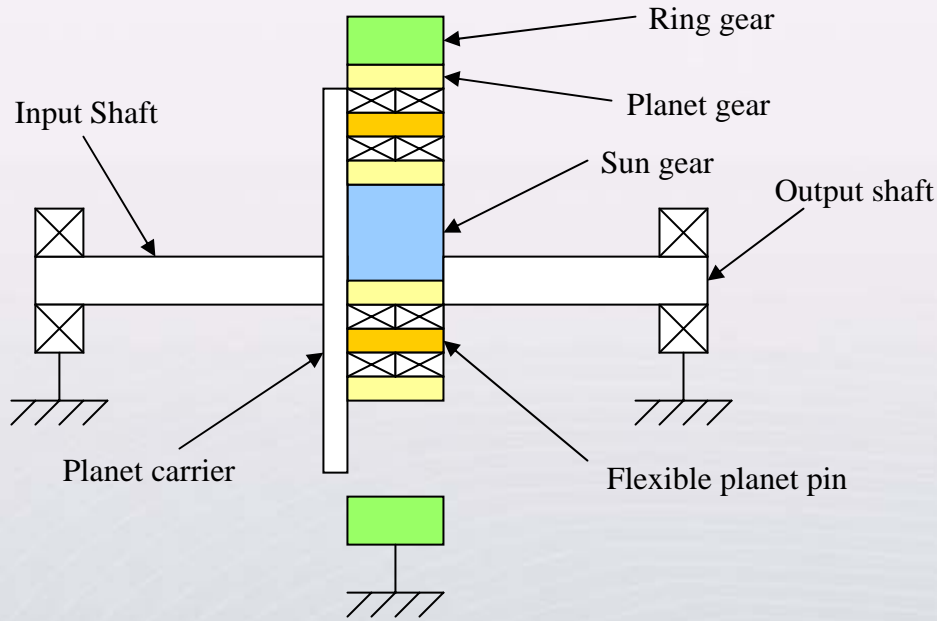

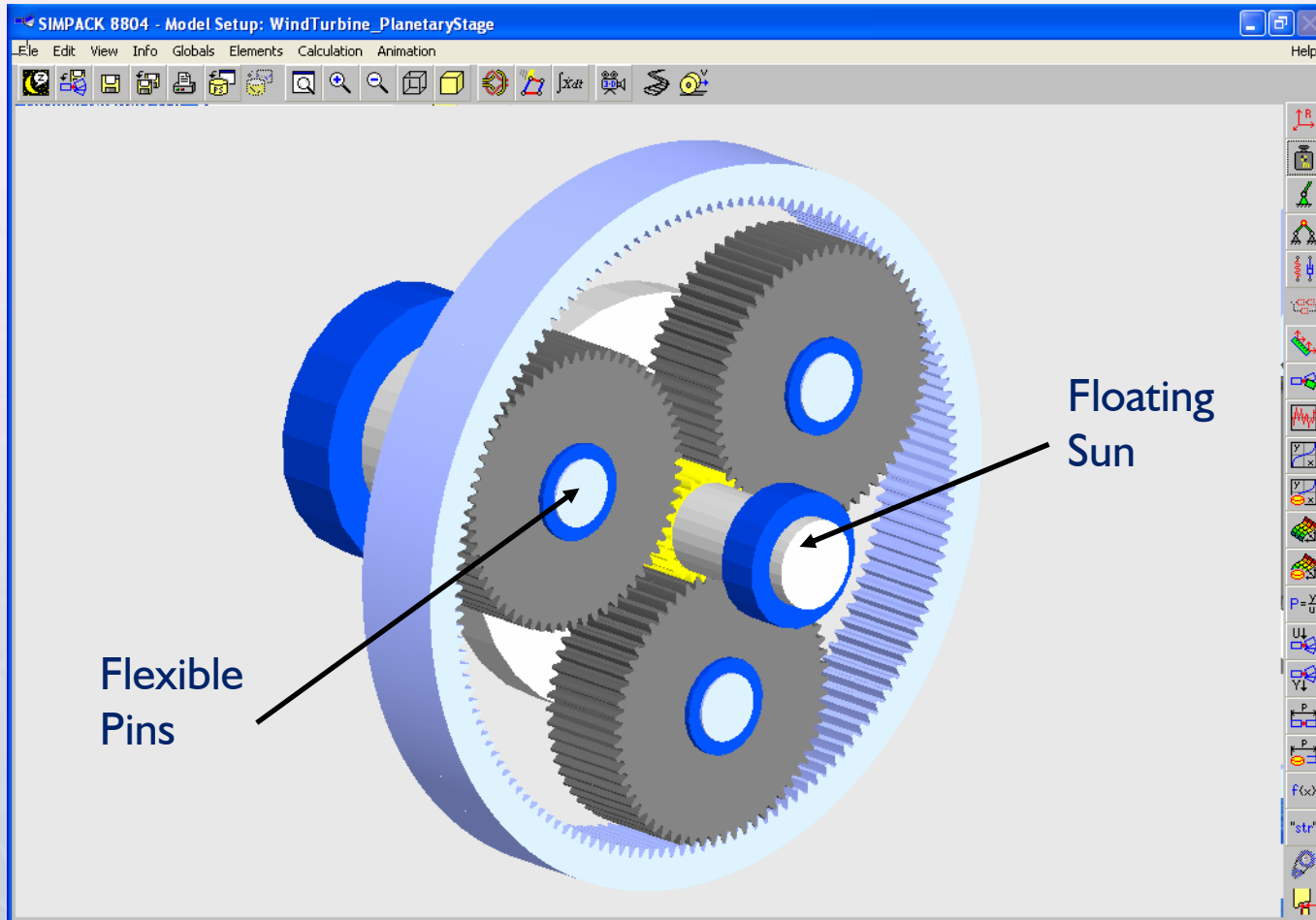

- Quasi-static analysis to compare the planet load share and whirling of the sun and carrier when the system rotates slowly (1 RPM)
- The dynamic analysis when the system rotates at high speed (80 RPM)
- In both cases the stiffness of the planet pins were changed from $1e6$ N/m to $1e7$ N/m.
- The analysis was performed with 40%, 60%, 80% and 100% of the rated torque.

- Planet load share is the load (torque) carried by each planet at a given instant in time.
- The planet load share varies with load, due to gravitation effects which dominate the load share at low loads.
- The planet load share results from Simpack were verified using results from a similar model in RomaxDesigner.
- As RomaxDesigner only carries out quasi-static analysis, the Simpack simulations were carried out at low speed to minimise acceleration/centripetal effects not modelled in RomaxDesigner

Planet Load Share



Planet load share versus torque

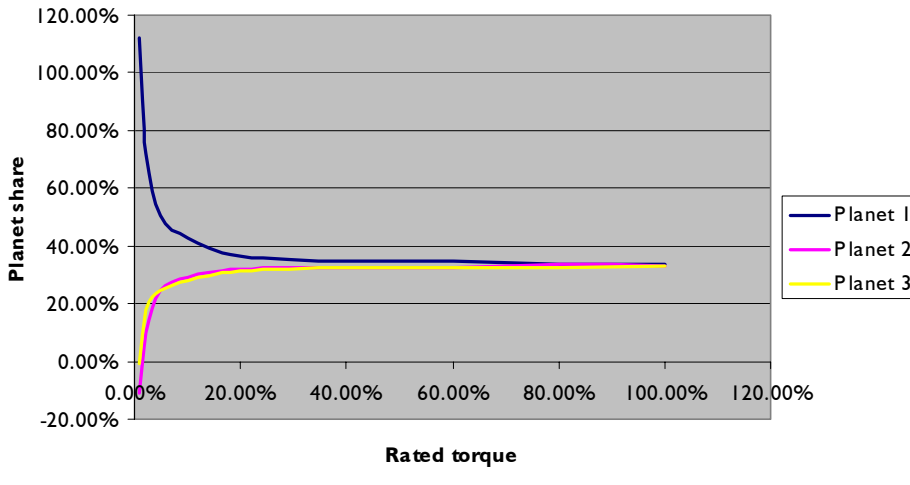

RomaxDesigner results

Planet load share

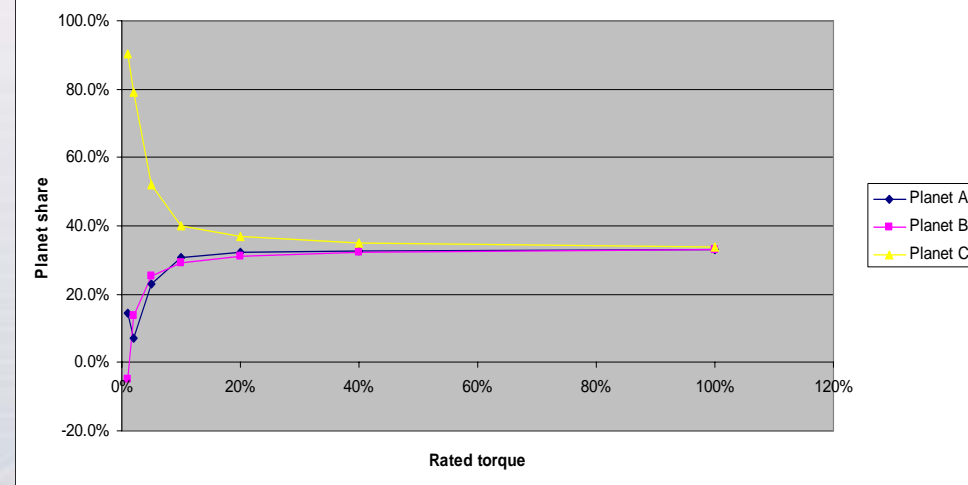

Simpack results

- Precession of the sun or planet carrier is the motion of the centre of the Sun gear or planet carrier.
- Due to fluctuations in the loads between the sun and planets both the sun and planet carrier centres will tend to follow an orbital path.

Quasi-Static Precession (linear) rotation at 1 RPM

Sun_precession

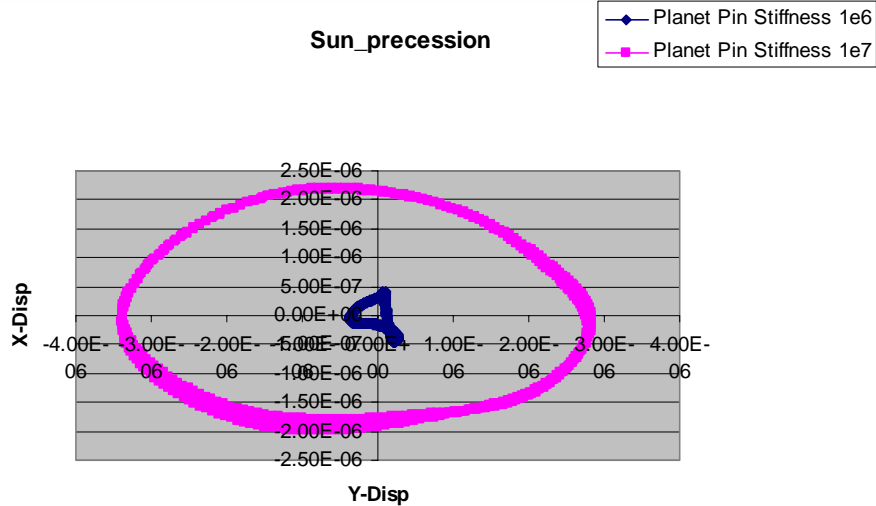

Simpack bushing linear bearing

Carrier_precession

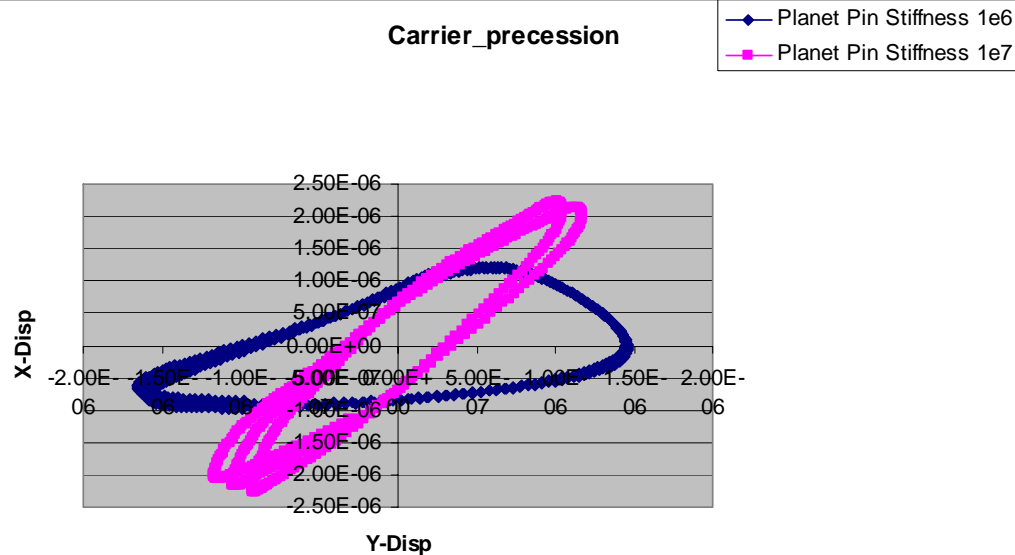

Quasi-Static Precession (All loads) rotation at 1 RPM

Simpack_bushing_Sun_precession

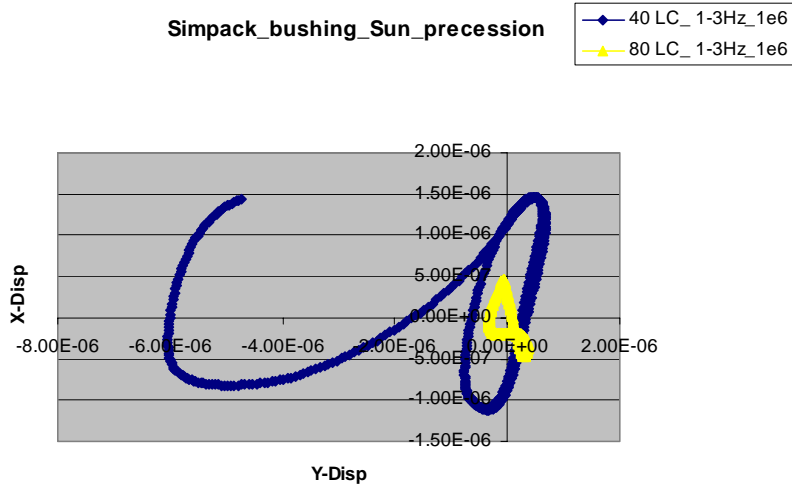

Simpack_bushing_Sun_precession

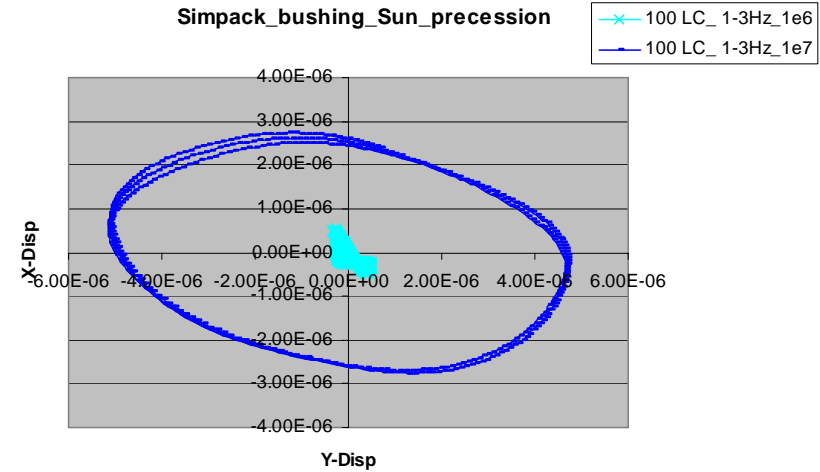

Simpack_bushing_Carrier_precession

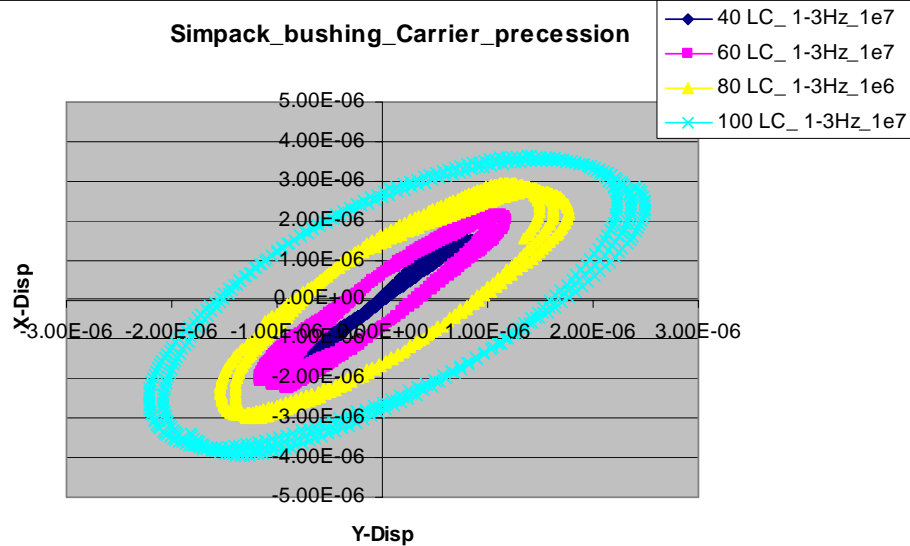

Sun

- The motion of the sun shows that with the softer planet pin there is a mode of vibration of the system with a similar frequency to the planet passing frequency.
- At all loads the stiffer pin increases the level of vibration (whirl) of the sun.

Planet Carrier

- In case of the carrier, similar trends are observed. The stiffer planet pin increases the vibration slightly compared to the softer pin.
- However in both the sun and carrier the whirl in case of 40% load at $1e6$ N/m has increased vibration and is comparable to the planet pin stiffness at $1e7$ N/m.

Dynamic Precession (linear) rotation at 80 RPM

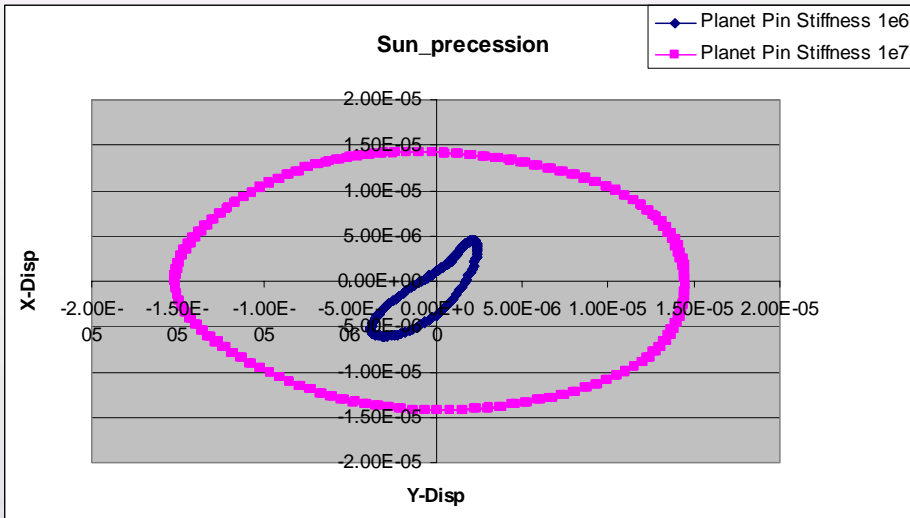

Simpack bushing linear bearing

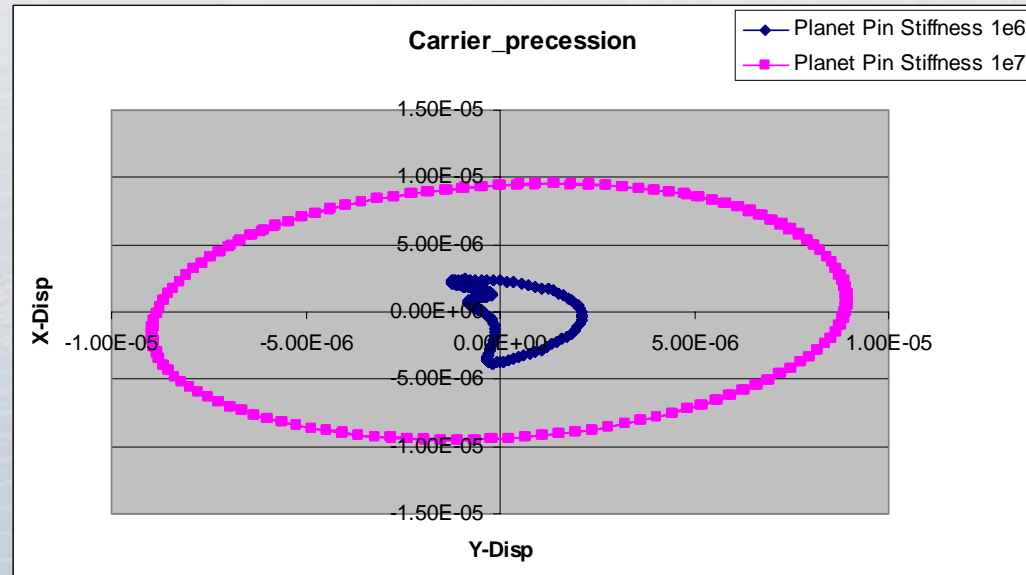

Dynamic Precession Results

Planet Passing Vibration



Planet passing vibration (3 times input frequency)

Sun

- The motion of the sun shows that with the softer planet pin there is a mode of vibration of the system with a similar frequency to the planet passing frequency.
- At all loads the stiffer pin increases the level of vibration (whirl) of the sun.

Planet Carrier

- The vibrations levels versus load also behave exactly as for the sun, with the stiffer pin reducing vibration as low loads, but increasing it greatly at higher loads.

- Romax has developed a bearing component for Simpack which allows Romax's accurate, non-linear bearing models to be incorporated into a Simpack model.
- In the model the planet bushings were replaced by the Romax bearings and both the Quasi-static and Dynamic analyses were repeated.
- Planet load share was obtained by running the model at 1%, 2%, 5%, 10%, 20%, 40%, 60%, 80% and 100% of the rated load.

Planet Load share (Romax non linear bearing in Simpack model)



Planet load share versus torque - based tangential forces

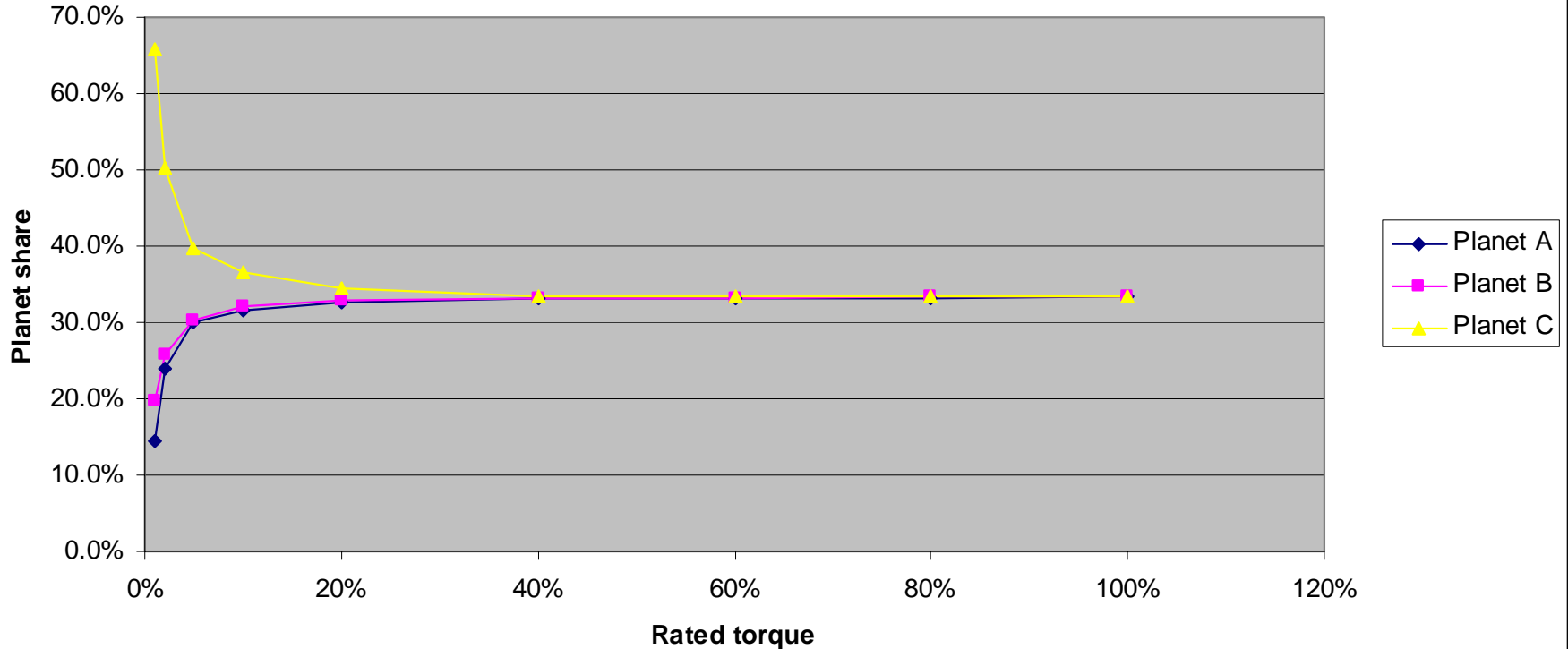

Quasi-Static Precession system rotation at 1 RPM

Romax_Sun_precession

- Planet Pin Stiffness 1e6
- Planet Pin Stiffness 1e7

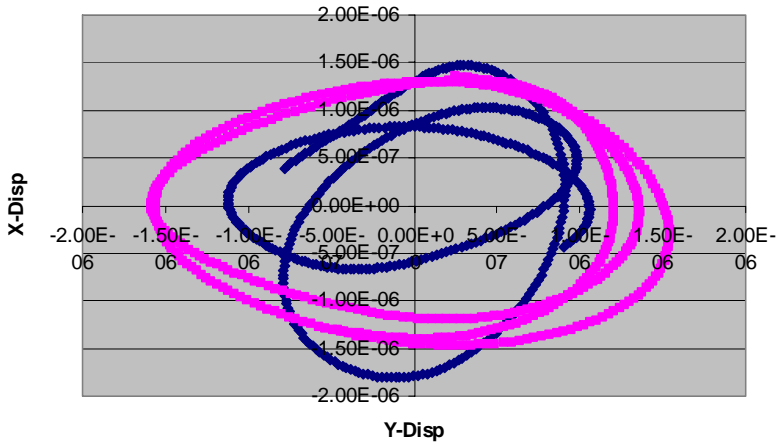

Romax non linear bearing in
Simpack model

Romax_Carrier_precession

- Planet Pin Stiffness 1e6
- Planet Pin Stiffness 1e7

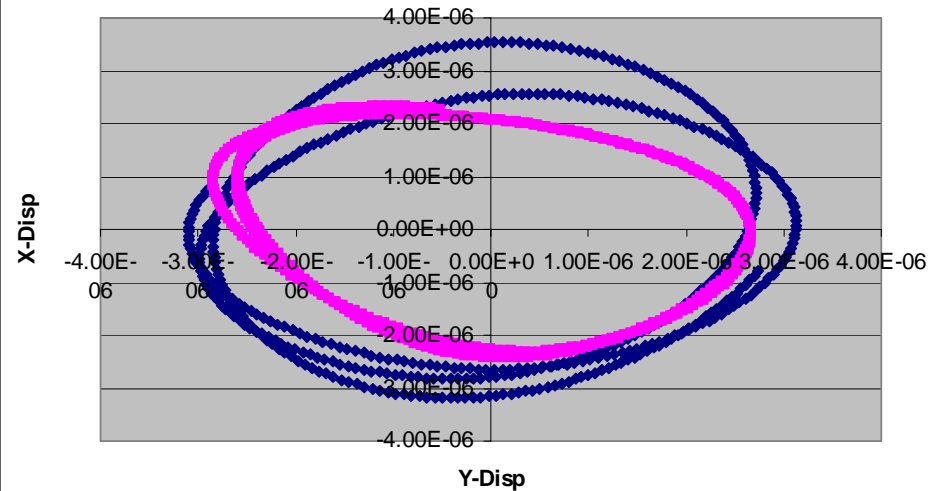

Quasi-Static Precession IRPM (Romax non linear bearing)

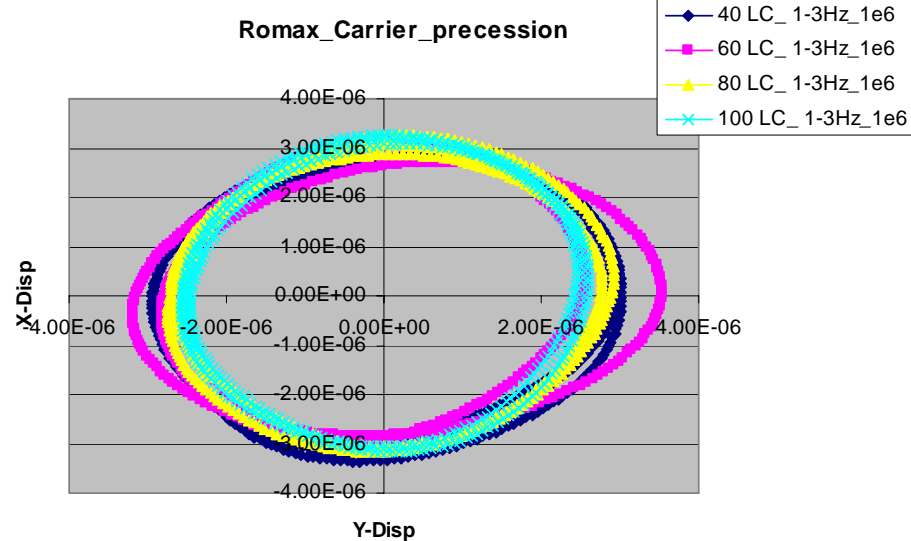
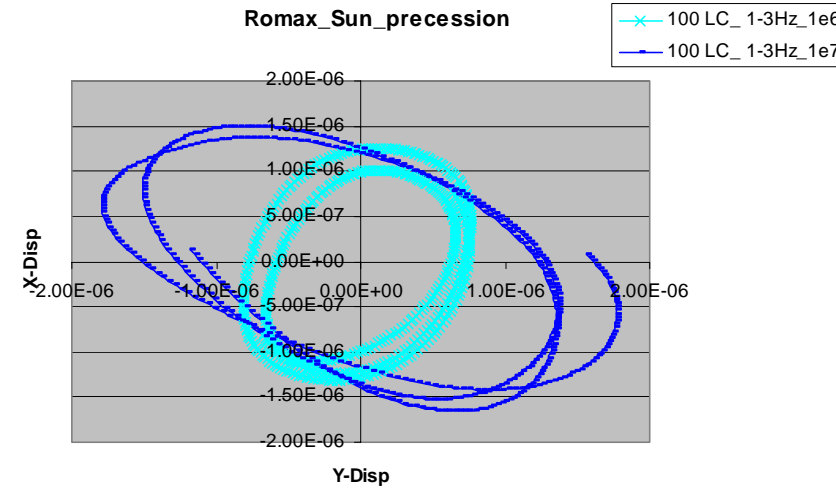
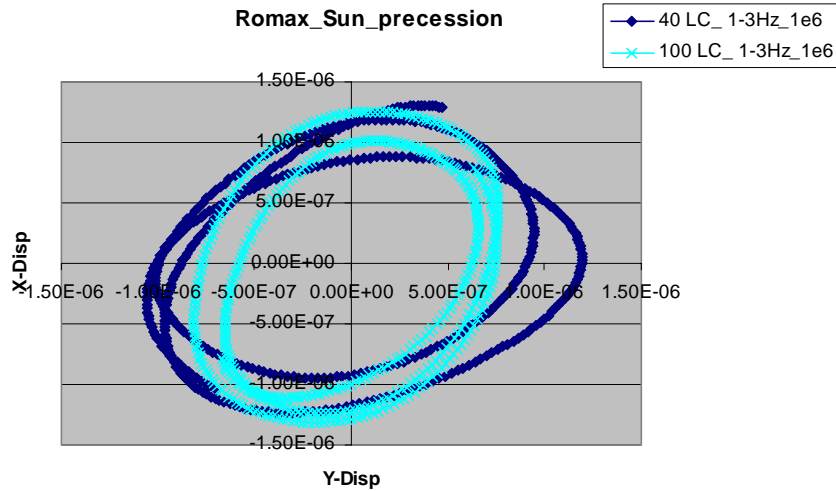

Quasi-Static Precession Results

system rotation at 1 RPM



Sun

- The motion of the sun shows that with the softer planet pin there is a mode of vibration of the system with a similar frequency to the planet passing frequency.
- At all loads the stiffer pin increases the level of vibration (whirl) of the sun.

Planet Carrier

- As with the sun gear, the motion of the planet carrier shows that with the softer planet pin there is a mode of vibration of the system with a similar frequency to the planet passing frequency.
- In case of the carrier, 40% and 60% load has less vibrations for stiffer pin than the softer pin. However for increased loads the stiffer pin increases the vibration slightly compared to the softer pin.

Dynamic analysis results (80 RPM)

Romax non linear bearing

Romax_bearing_Sun_precession

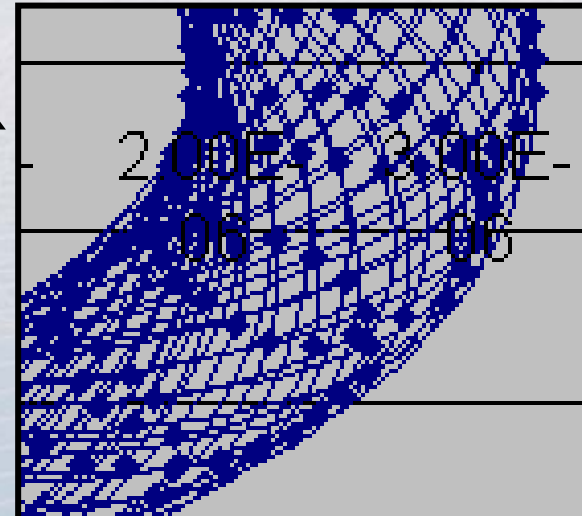
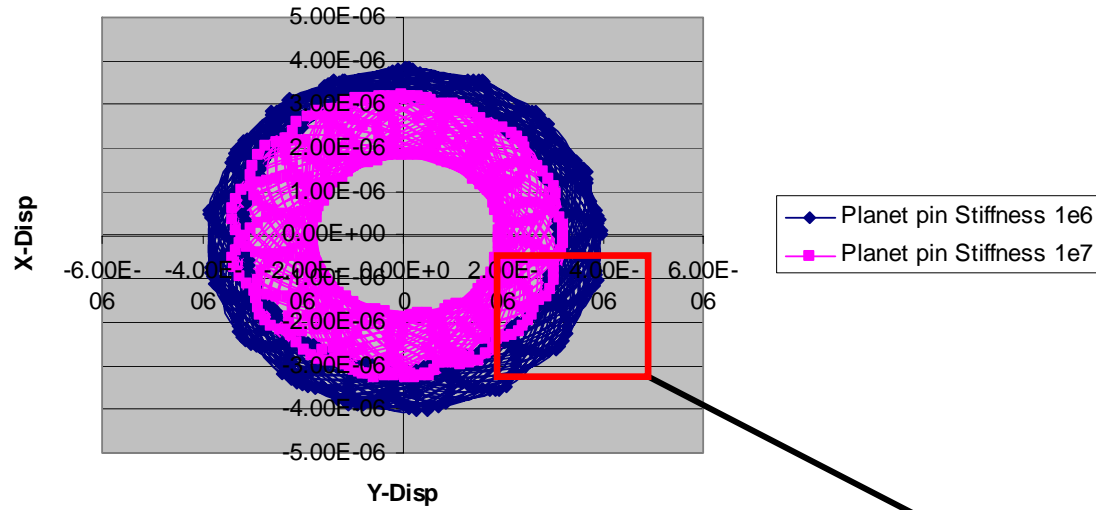

Dynamic analysis Results

system rotation at 80 RPM



Planet passing vibration (3 times input frequency)

Sun

- The motion of the sun shows that with the softer planet pin there is a mode of vibration of the system with a similar frequency to the planet passing frequency.
- The stiffer pin reduces the level of vibration (whirl) of the sun in case of the non-linear bearings.

Planet Carrier

- The vibrations levels versus load also behave exactly as for the sun, with the stiffer pin reducing vibration.

Bearing forces

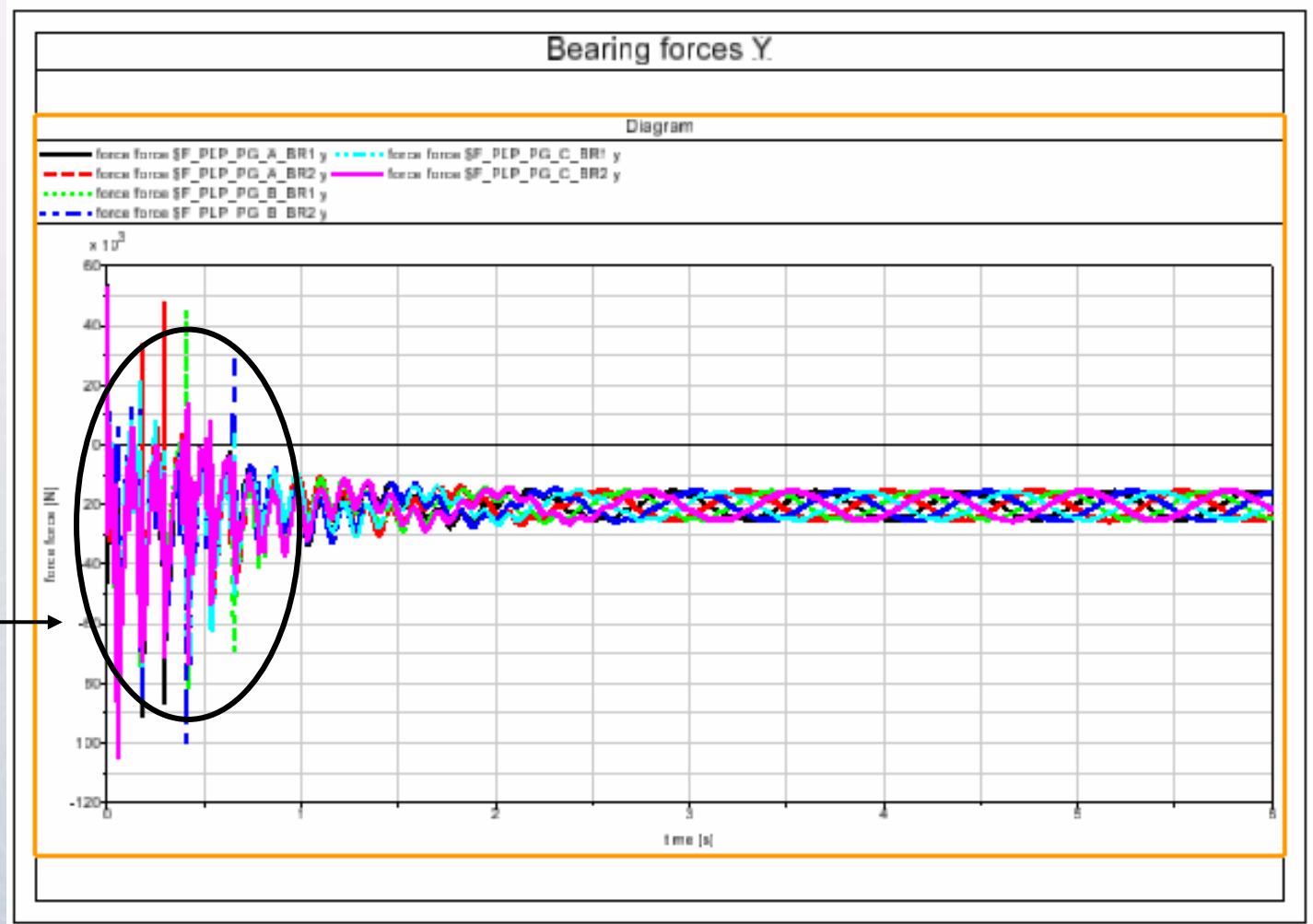

Bearing forces during transient period of the step input.



The whirl diameter of the carrier is approximately 200 μm during transient period

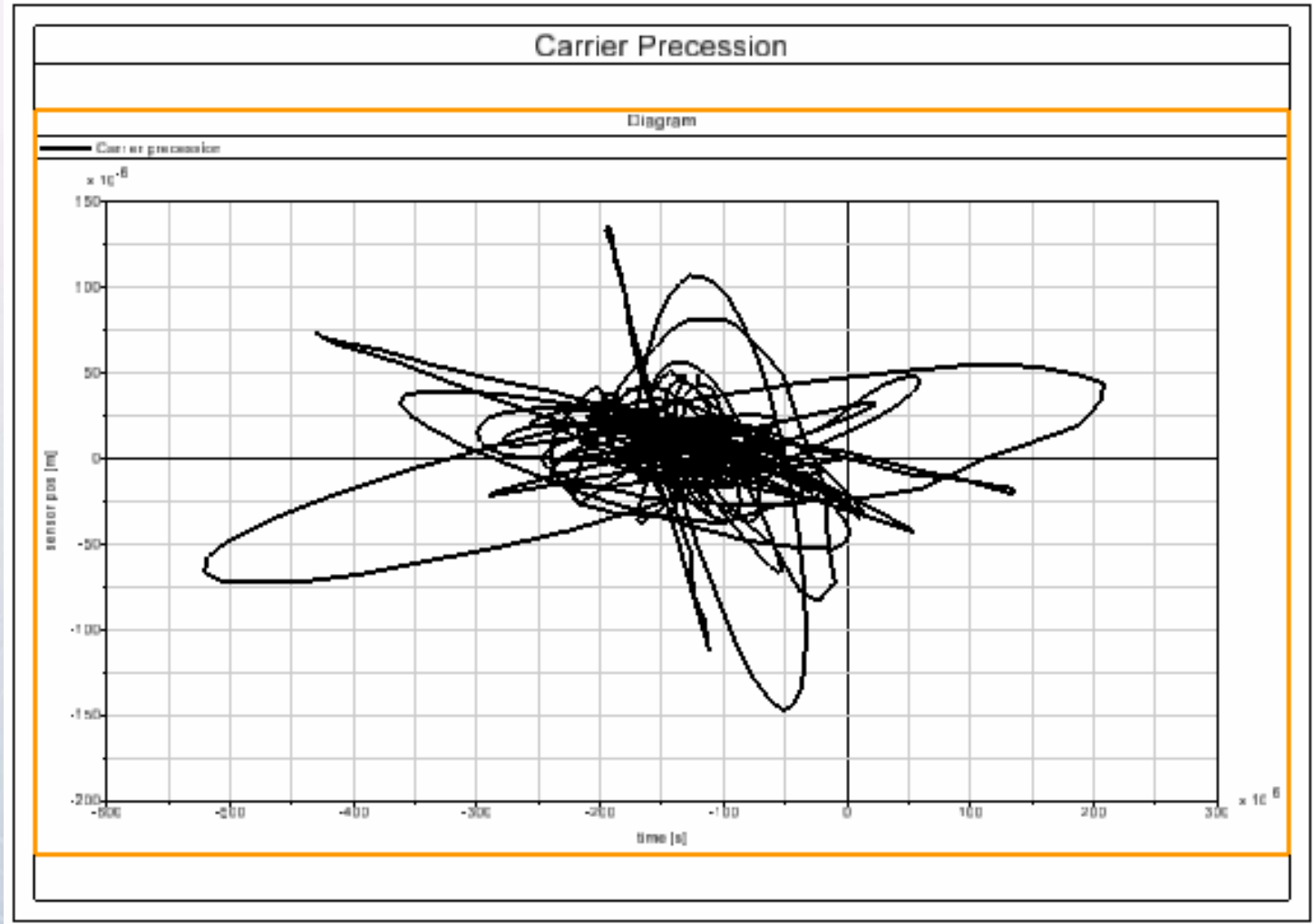
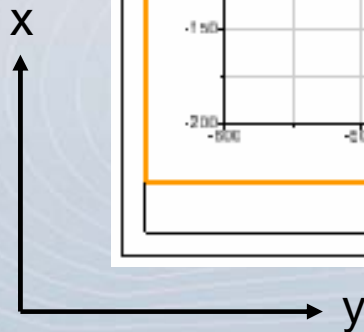

The whirl diameter of the Sun is approximately 800 μm during transient period

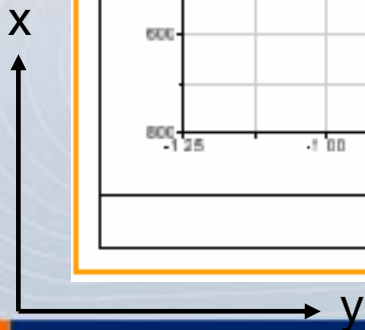
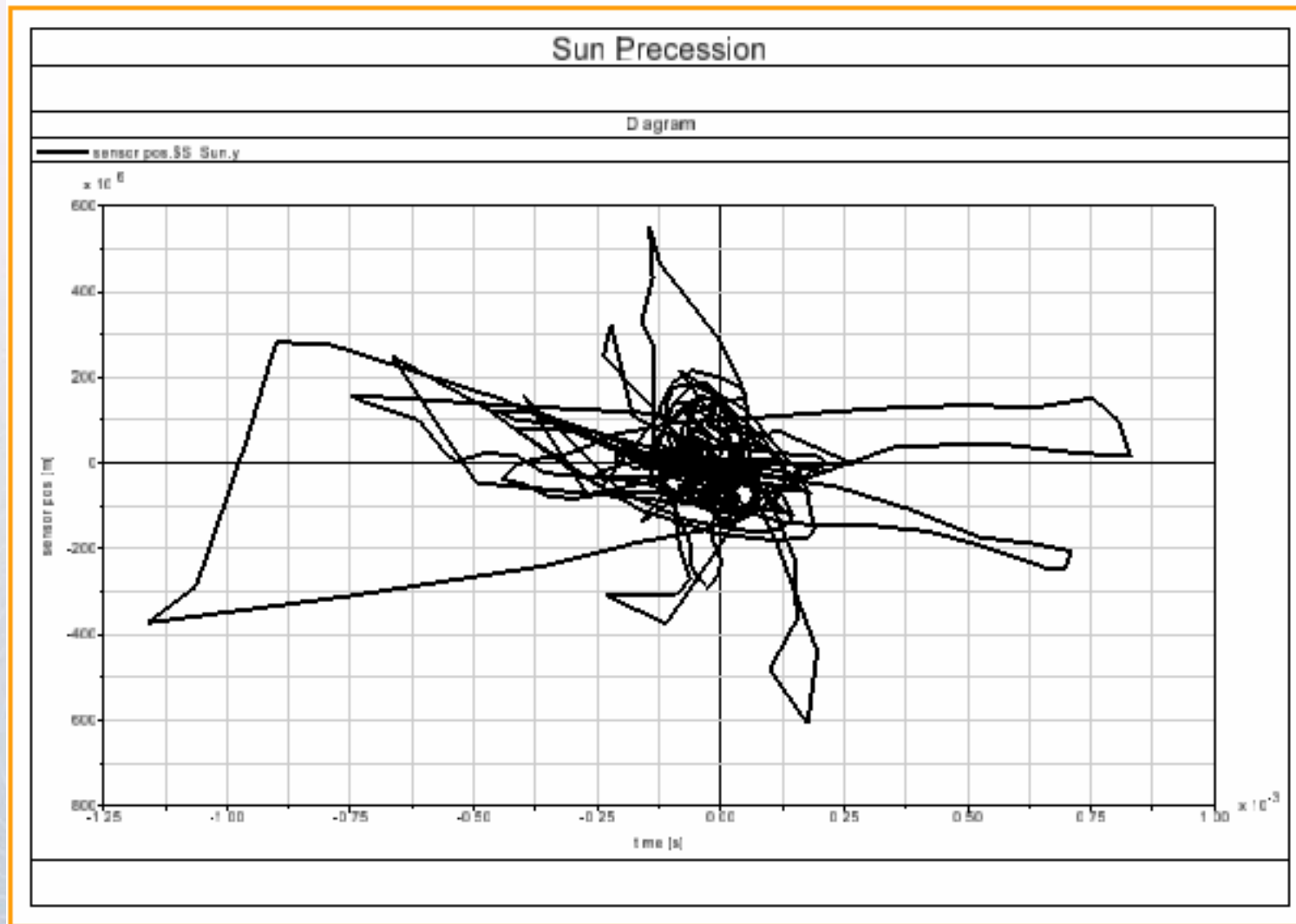

- The results are compared with the Romax non-linear bearings and Simpact bushings element.

Quasi-Static Precession Results system rotation at 1 RPM

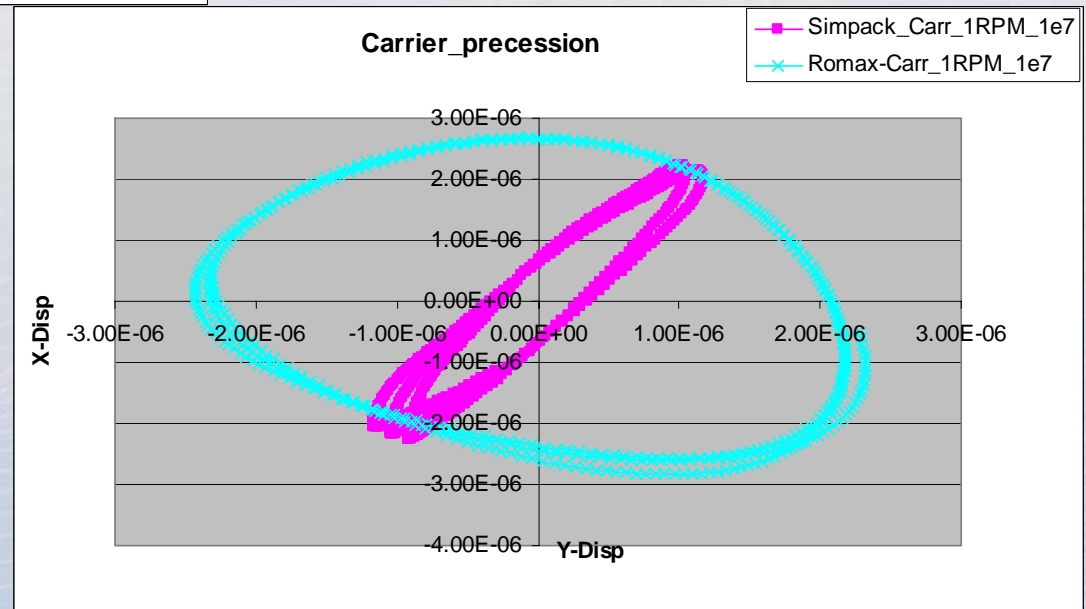
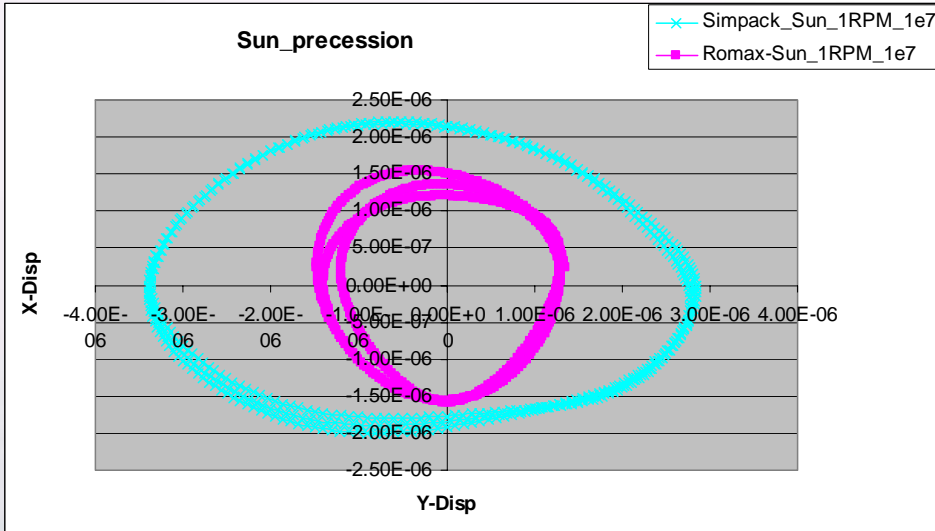

Quasi-Static Precession Results system rotation at 1 RPM

Sun_precession

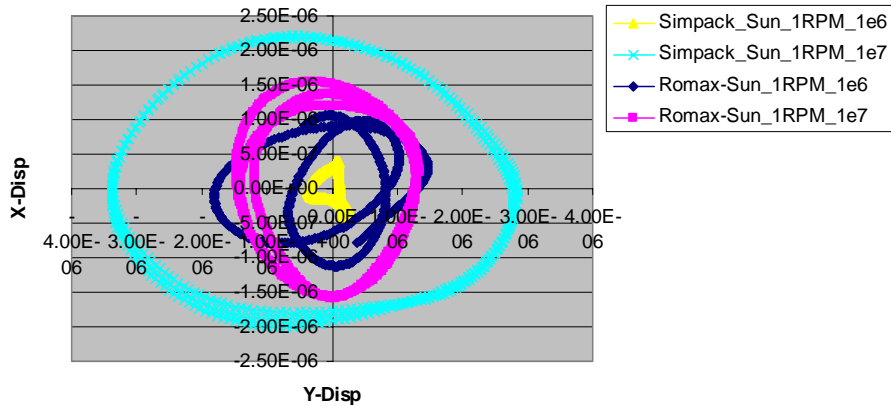

Carrier_precession

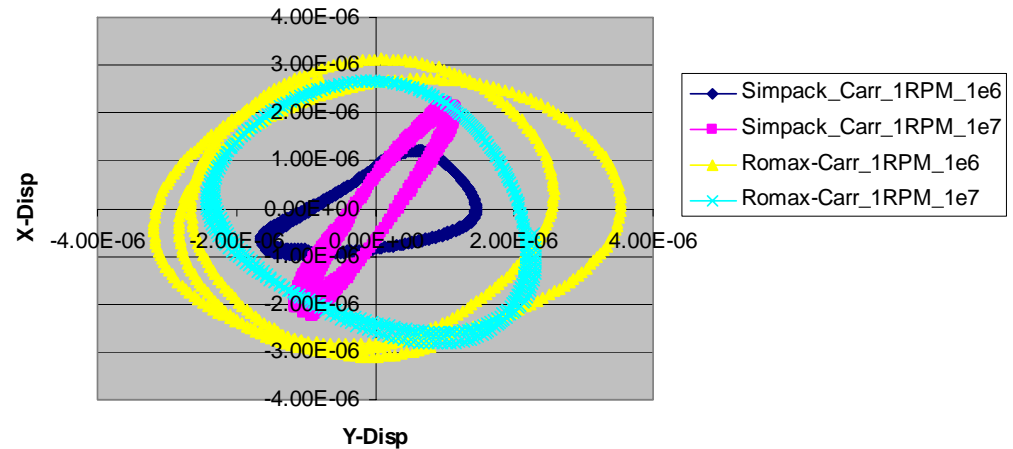

Dynamic Precession Results system rotation at 80 RPM



Sun_precession

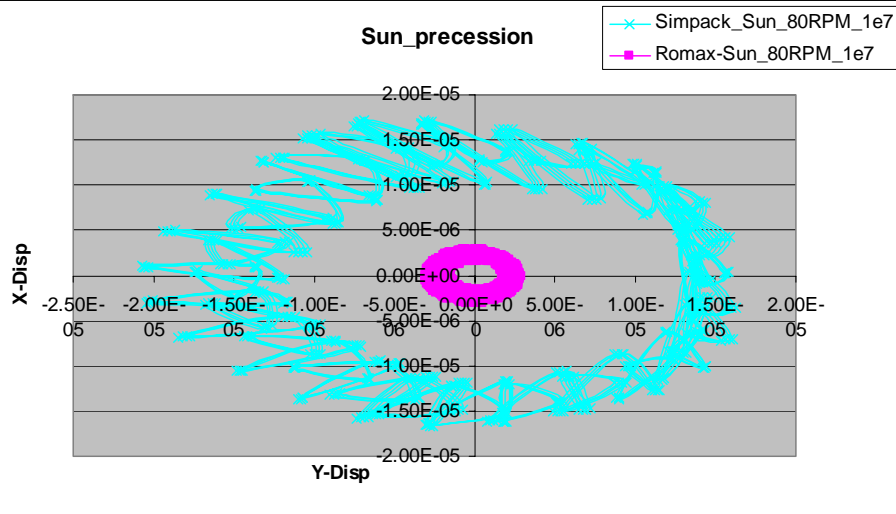

Carrier_precession

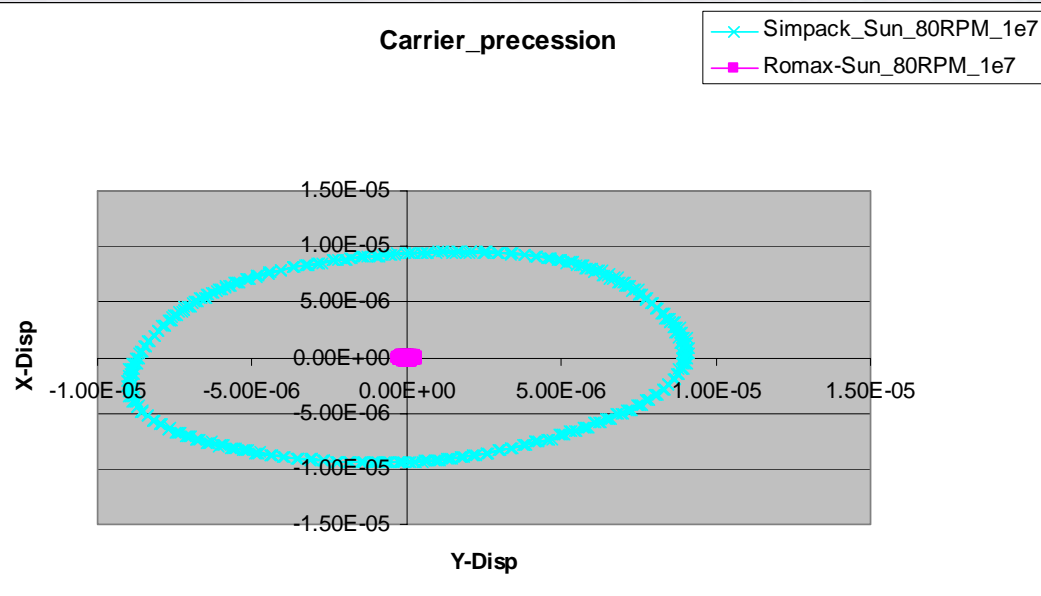

Dynamic Precession Results

system rotation at 80 RPM



Sun_precession

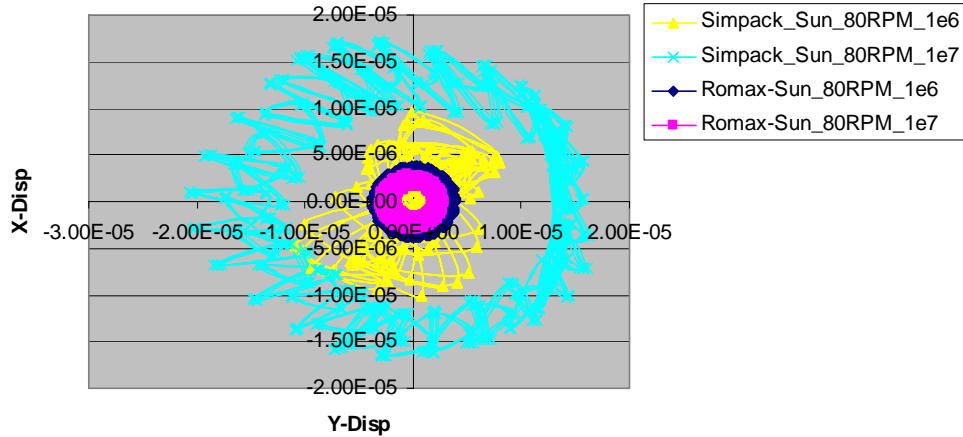

Carrier_precession

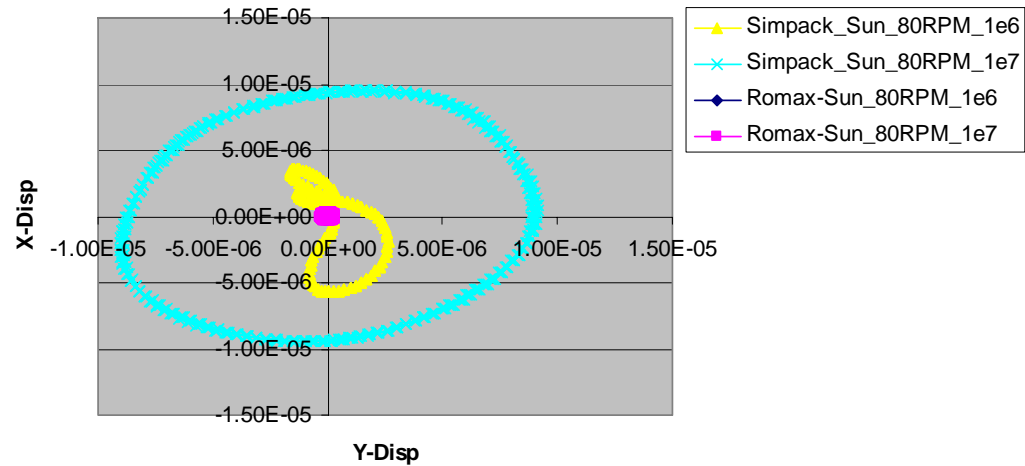

- Similar trends for planet load share are observed for Simpack bushing element and Romax non-linear bearings.
- However, non-linear models of bearings are necessary to accurately predict the precession behaviour of a planetary system in dynamic analysis as linear bushing model predicted increased precession.
- The whirl of the sun and carrier and hence the vibrations are sensitive to the planet pin stiffness. However this problem is reduced by flexible planet pin design that can absorb vibration.
- Nonetheless, MBS of complex systems, especially planetary systems, cannot give accurate results without sophisticated non-linear bearing models.

Delivering Engineering Excellence

Romax Technology

UK Head Office

Rutherford House
Nottingham Science and Technology Park
Nottingham
Nottinghamshire
NG7 2PZ
United Kingdom

T: +44 (0)115 951 8800

F: +44 (0)115 951 8801

E: info@romaxtech.com

www.romaxtech.com



THE QUEEN'S AWARDS
FOR ENTERPRISE:
INTERNATIONAL TRADE
2004

