

# Dynamical Simulation of Gear Shift Processes in BMW Motorcycle Gear Boxes.

Roland Zettler, BMW Group

Matthias Anders,  
Bastian Bredl,

Petar Baruncic



BMW Motorrad

SIMPACK  
User Meeting

Salzburg  
May 2011



Freude am Fahren

# Contents.



- Introduction: Motorcycle Gear Shifting
- 2005: Development of Force Element 67 by Dr. Nussbaumer, Dr. Bencker (BMW Group) and SIMPACK
- Adaption of Force Element 67 for Motorcycle Gear Boxes
- Shifting Process Simulation & Postprocessing
- Gear Box & Drivetrain Modelling
- Randomization and Parameter Variation
- Shifting Comfort Evaluation
- Summary / Outlook

# Motorcycle Shifting Process. Basics.

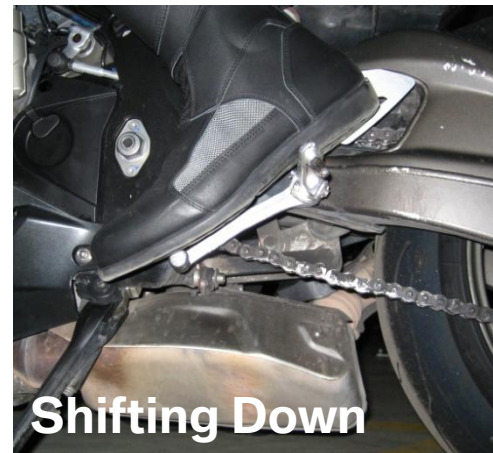
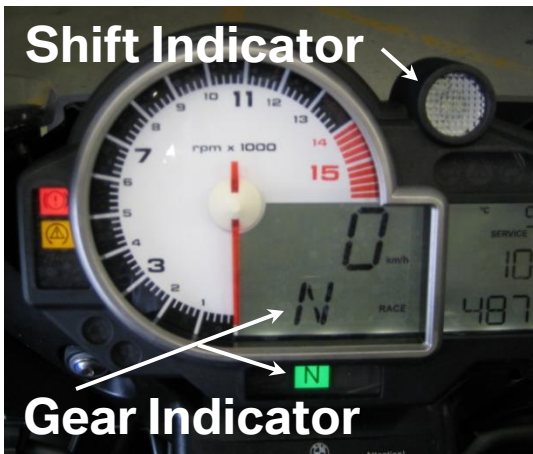

Gear step 2 - 6



Neutral  
(N)



Gear step 1

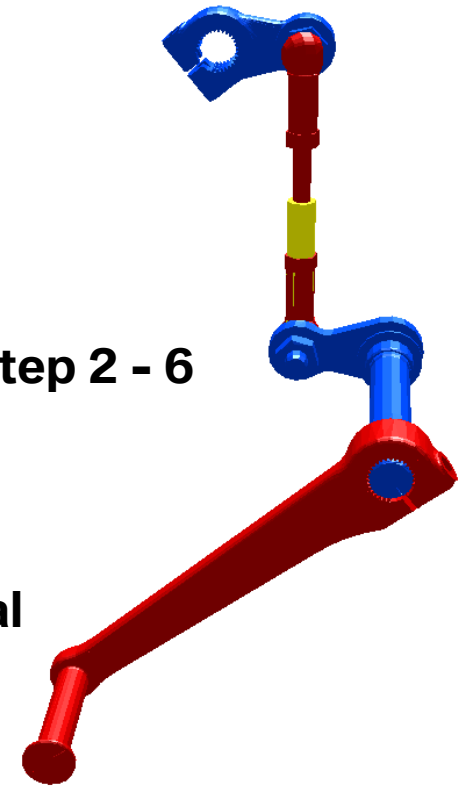

- **Neutral** between 1st and 2nd gear
- **Sequentially** shifting only
- Power shifting possible (shifting w/o clutch; **shifting assistant** w. engine control intervention)
- Gradual increase of **CVT**, **dual clutch** and **automated shifting** market shares

# Motorcycle Shifting Process. Gear Box Design.



Freude am Fahren

- **straight-cut** gear wheels with **sliding gears** or
- **helical-cut** with **selector sleeve** are mainly used
- engagement is achieved by constant-mesh **dog-window** contact
- **conflict of objectives:** dog-/window clearance is crucial both for engaging and load alteration

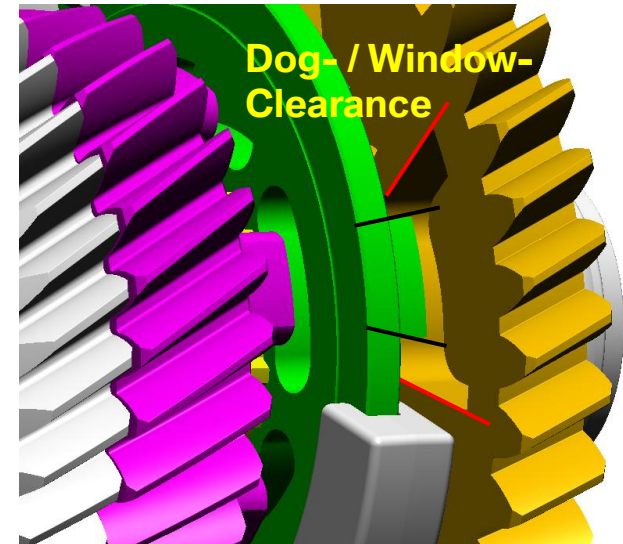
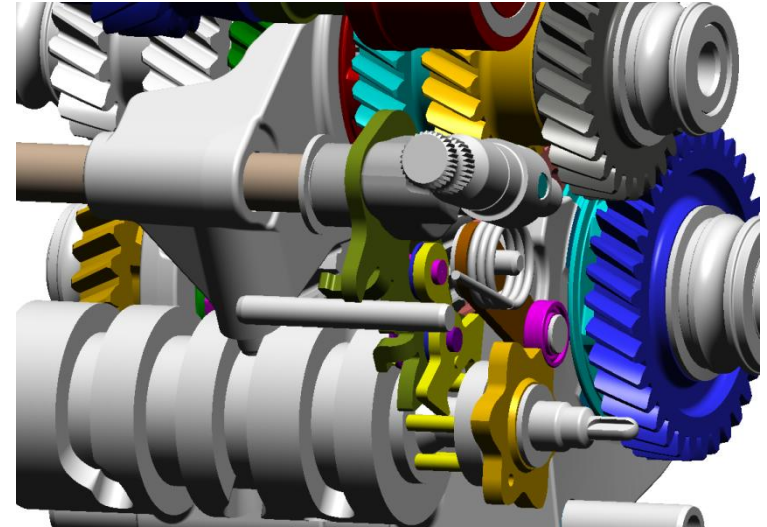
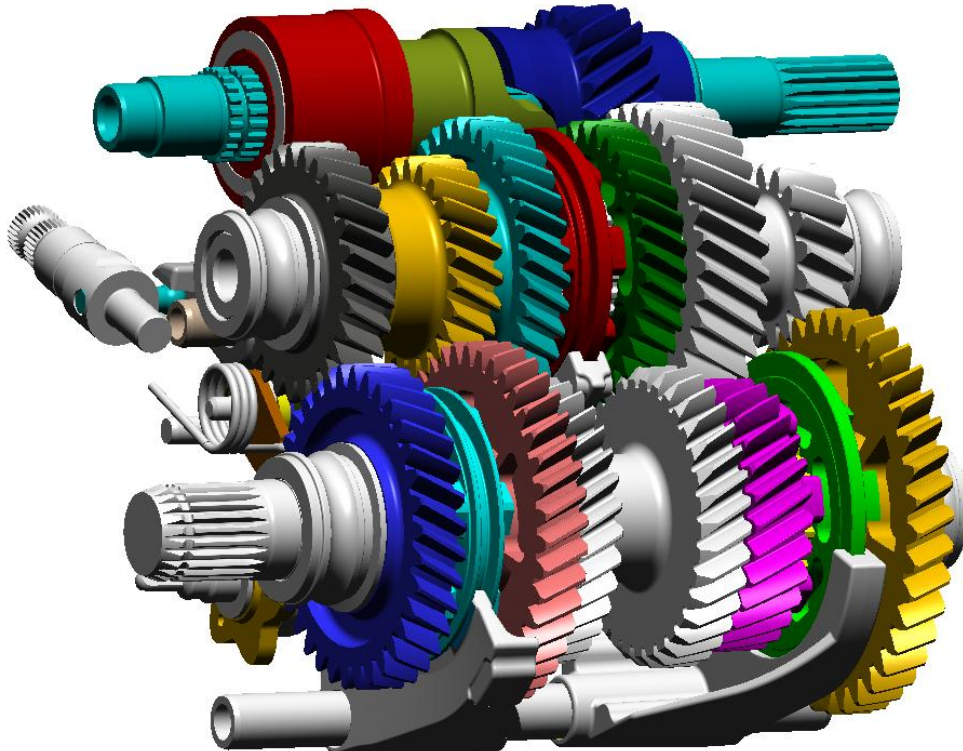

# Shifting Process Simulation.

## History of FE 67.

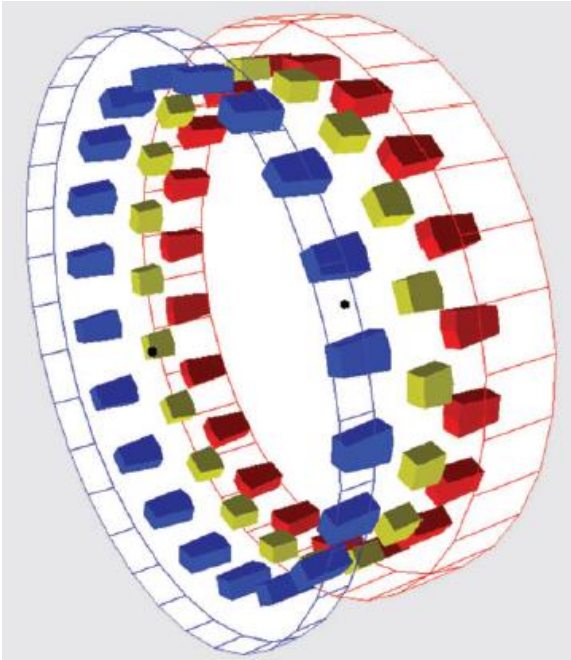

### SIMPACK News 07/2005

- Development of a **force element** based on a **user routine** by Dr. Nussbaumer and Dr. Bencker (BMW Group) in cooperation with SIMPACK
- FE 67 models interaction of two gears located on the same (non-elastic) axis
- Contact between the gearing can occur at different positions along the teeth
- Contact model is of analytical nature

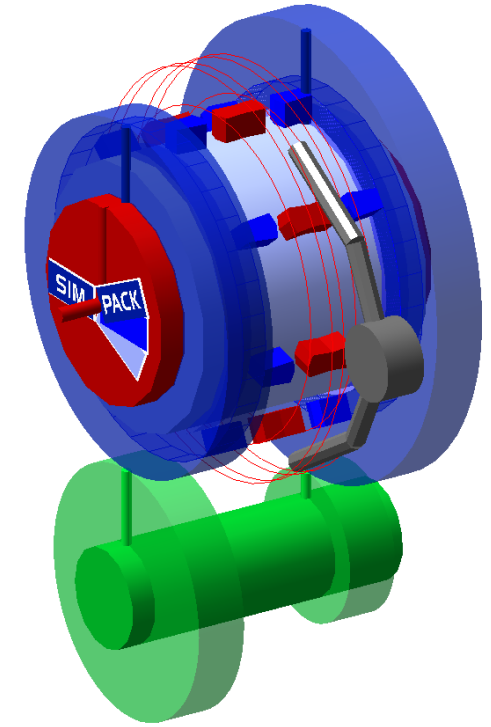
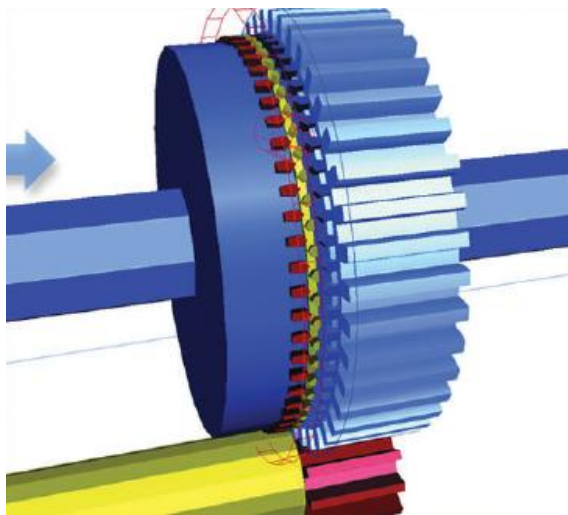

### SIMPACK Example Model

→ FE 67 available in the **Driveline Package**

# Shifting Process Simulation.

## Adaption of FE 67.

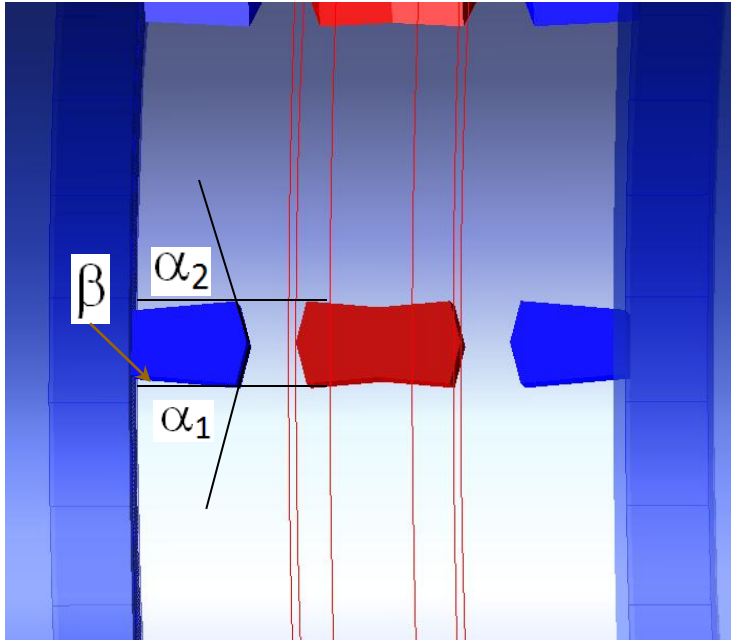

### „Classic“ Model Configuration

- number of dogs
- friction coefficient
- contact stiffness
- contact damping
- ...

**Model Adaption**  
in order to satisfy  
constant-mesh  
dog-window gear  
wheels

Alpha-beta-plane radius  
implemented

$$\alpha_1, \alpha_2 \rightarrow 90^\circ$$

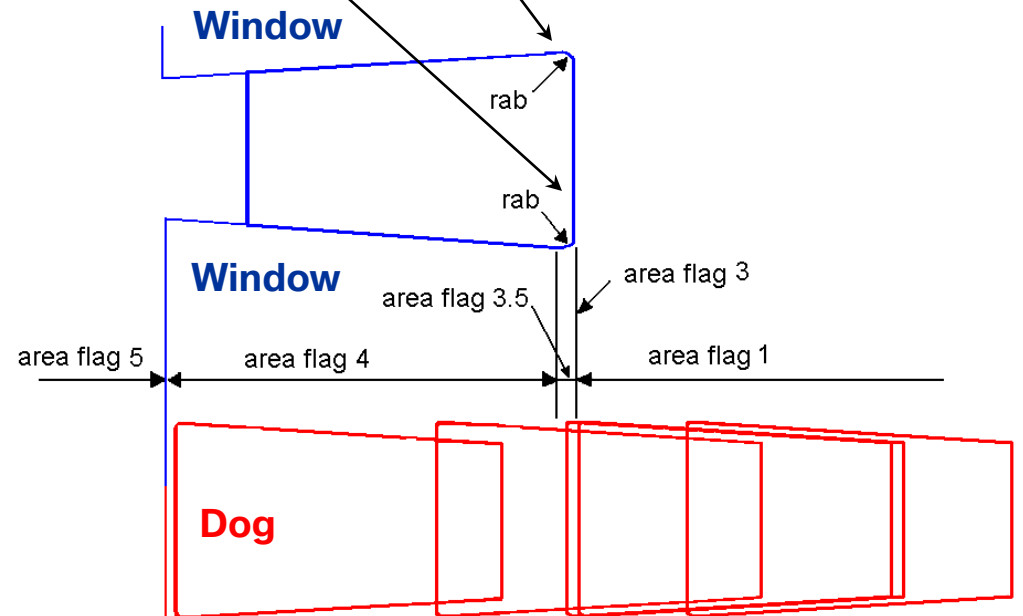

# Shifting Process Simulation. Basic Modelling.

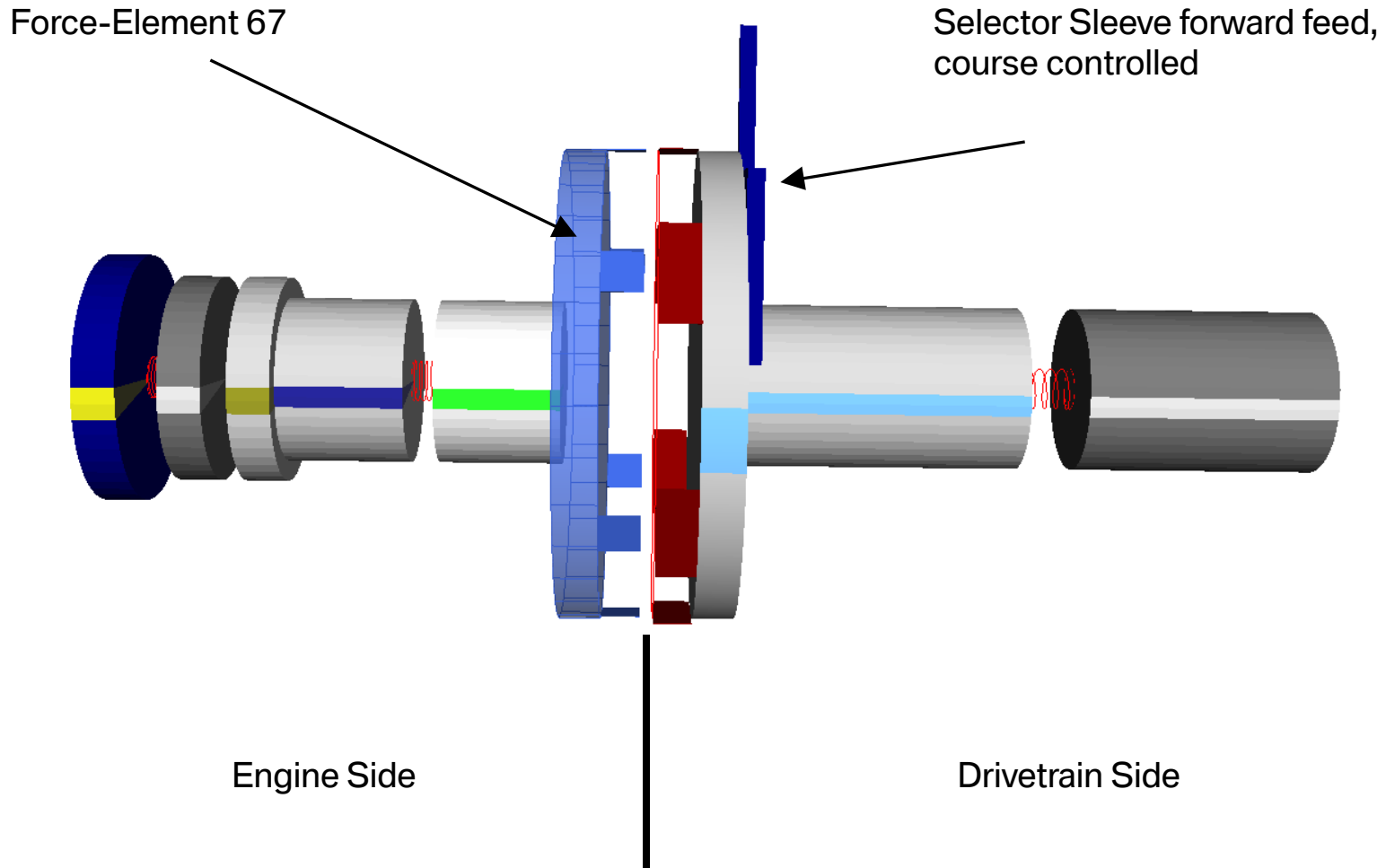

# Shifting Process Simulation.

## Postprocessing.

### Visualisation of blocking interval and blocking angle

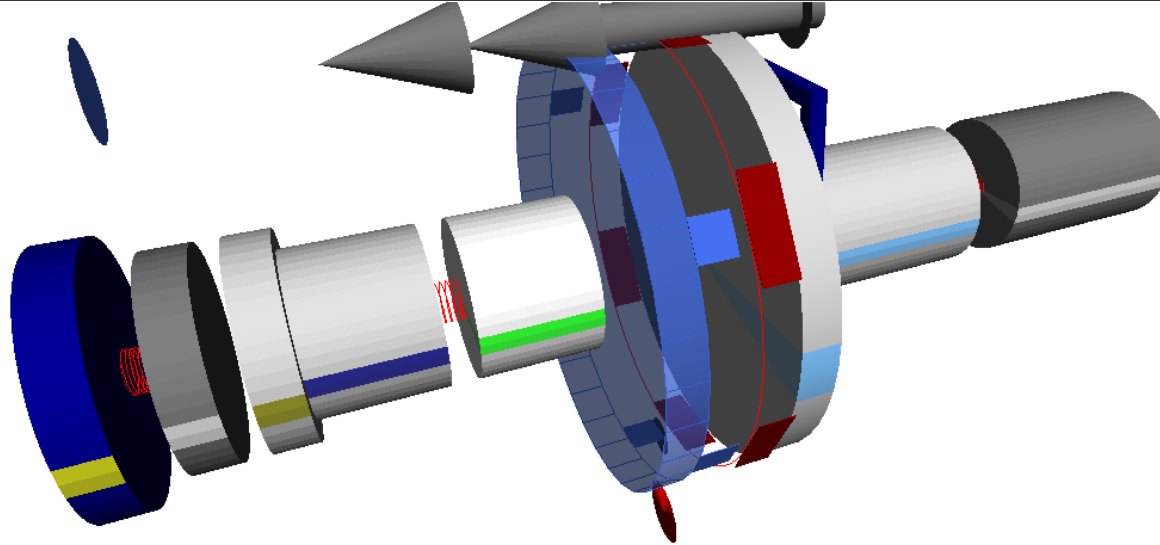

### Blocking interval

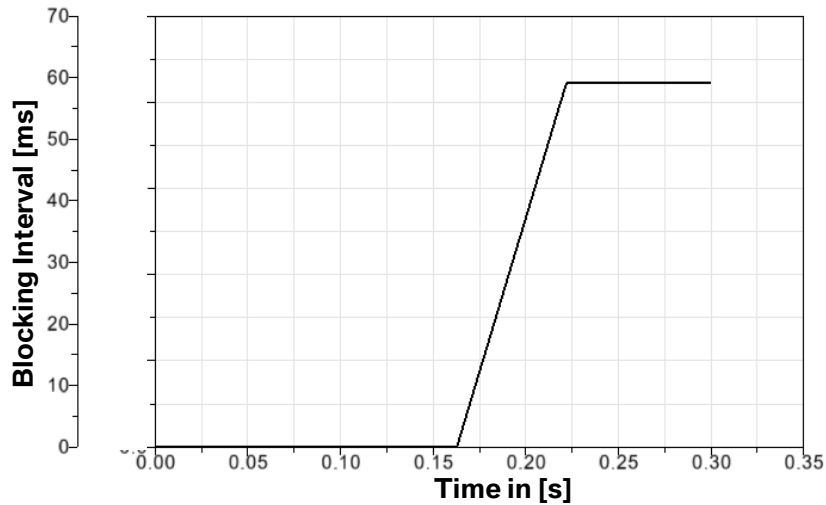

### Blocking angle

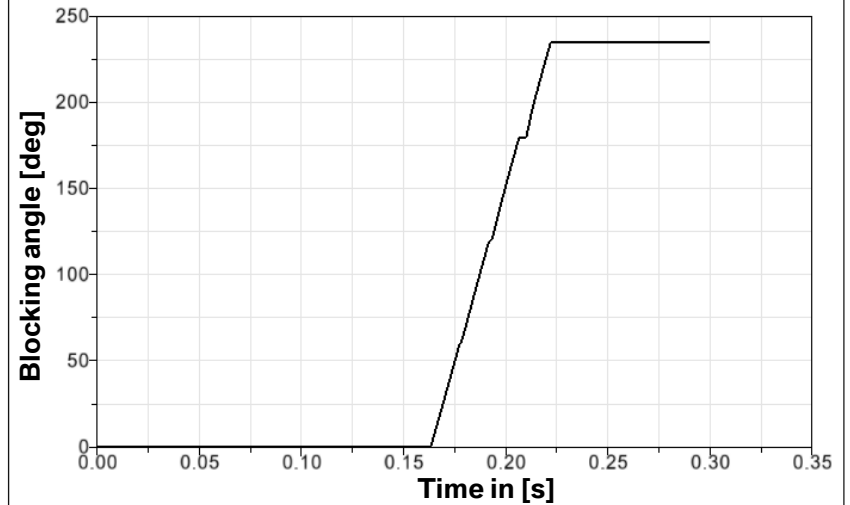

# Shifting Process Simulation.

## Gear Box Modelling.

### Gear box model

- one gear pair per substructure
- gear wheel by constraint type 14
- course-controlled selector sleeve (a.t. beginning)
- substructure coupling of gear box shifting control and shifting model (advanced models)

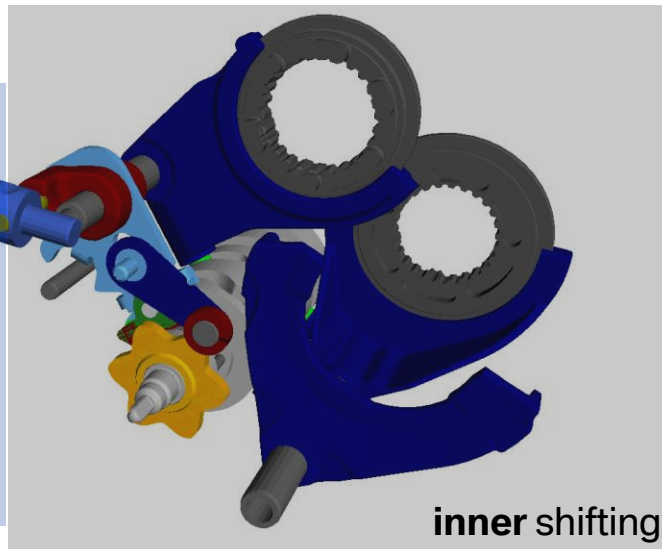
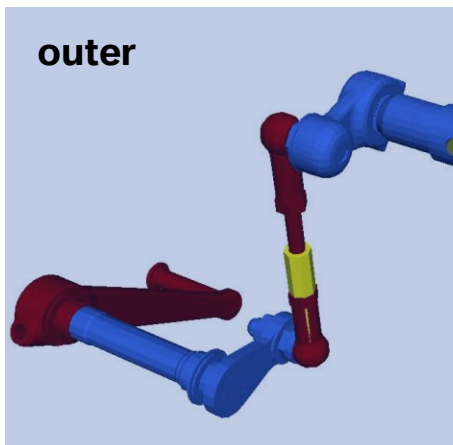
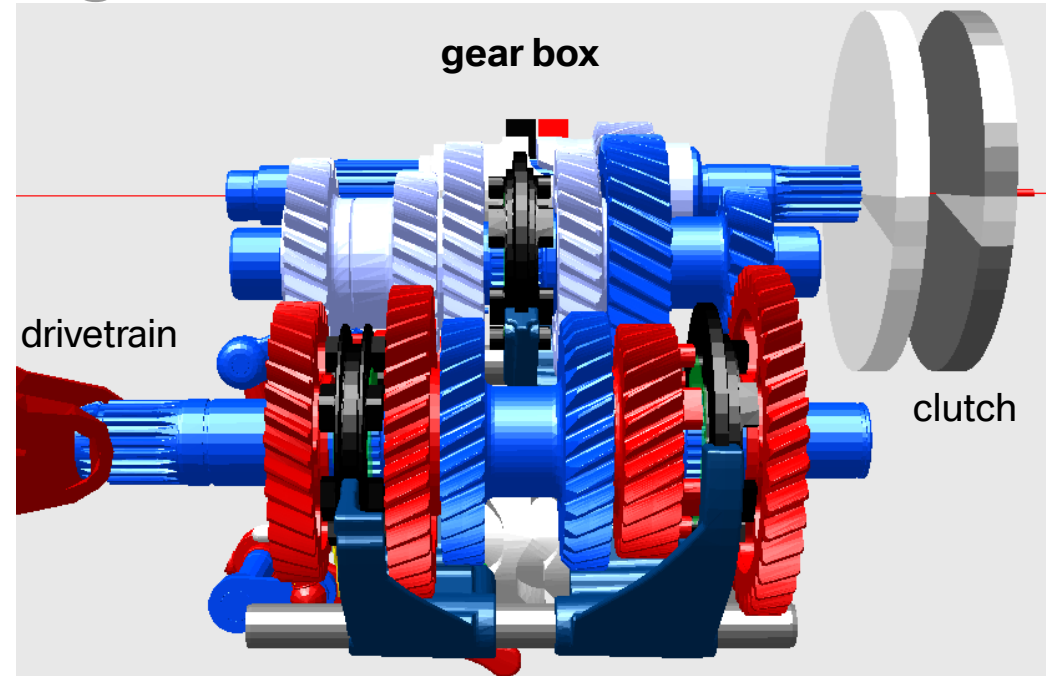

### Shifting model

- FE 45 curve/curve
  - shifting star, arrestor lever
  - shifting retainer, cylinder wreath
- FE 18 unilateral spring damper
  - retainer stopper
  - shifting drum contour
- substructure coupling of outer shifting and driver's foot substructure

# Shifting Process Simulation.

## Drivetrain Modelling.

- Model environment extension: roller test stand with simplified tire behavior is modelled (slip behavior non neglectable)
- damping coefficient of cardan shaft must be evaluated
- model of driver's foot is important for force distribution

roller test stand

cardan shaft

driver's foot

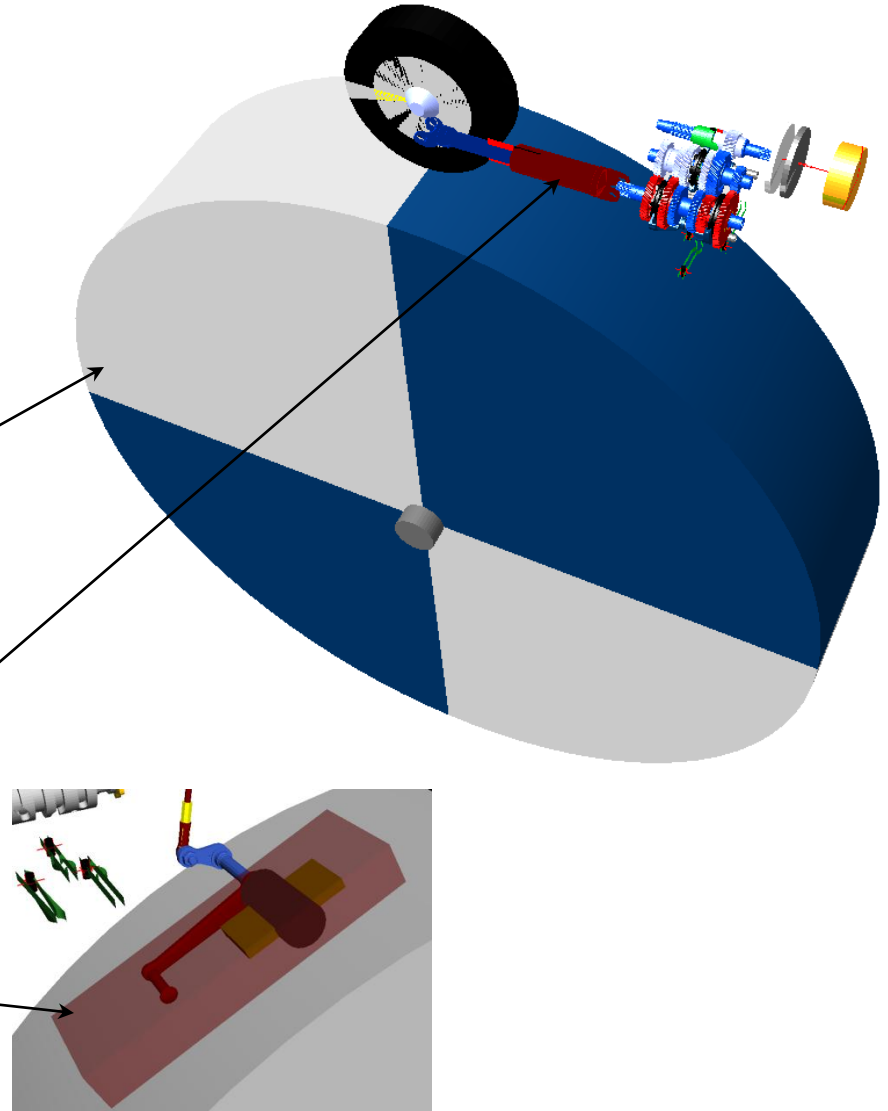

# Shifting Process Simulation.

## Drivetrain Modelling.

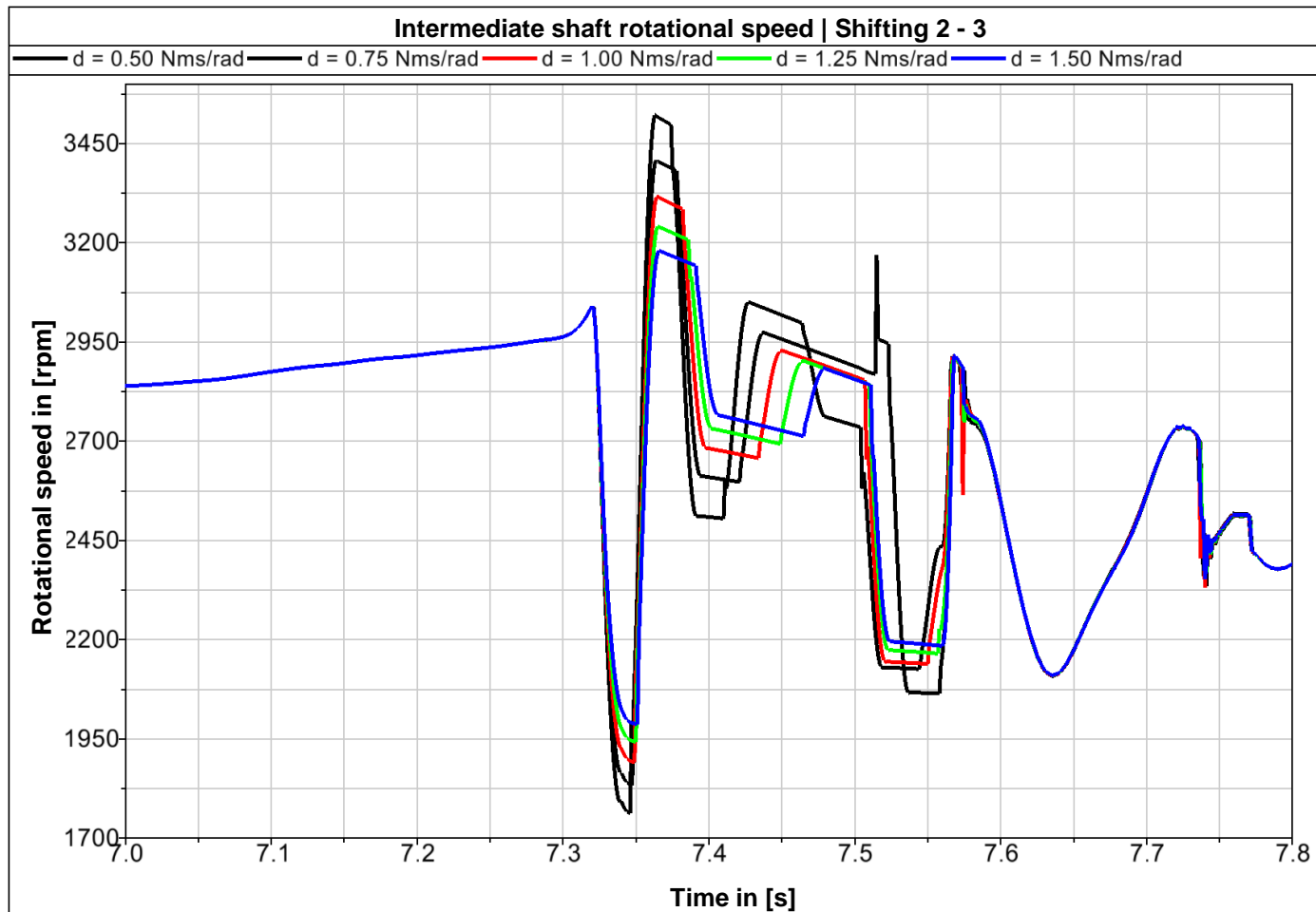

- Intense adaption of drivetrain parameters
- Evaluation of simulation models by test rig measurement runs

# Randomization and Parameter Variation. Shifting and Statistical Influence.

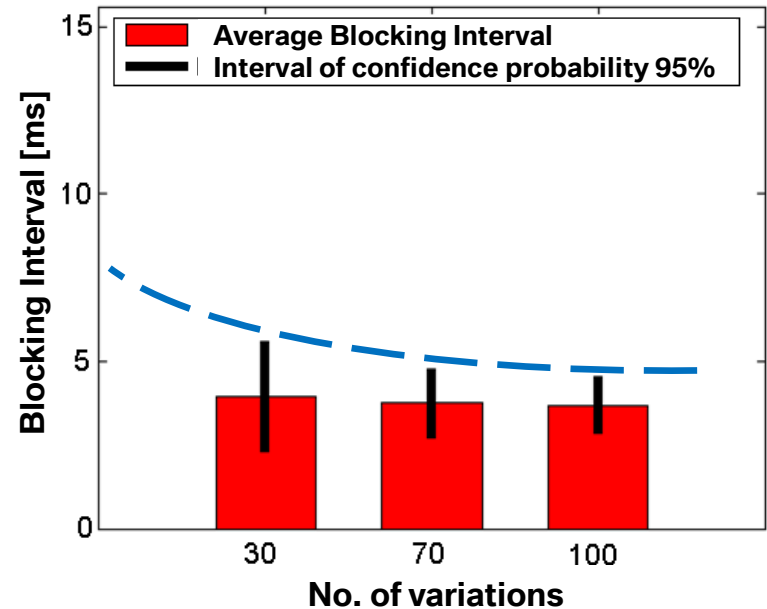
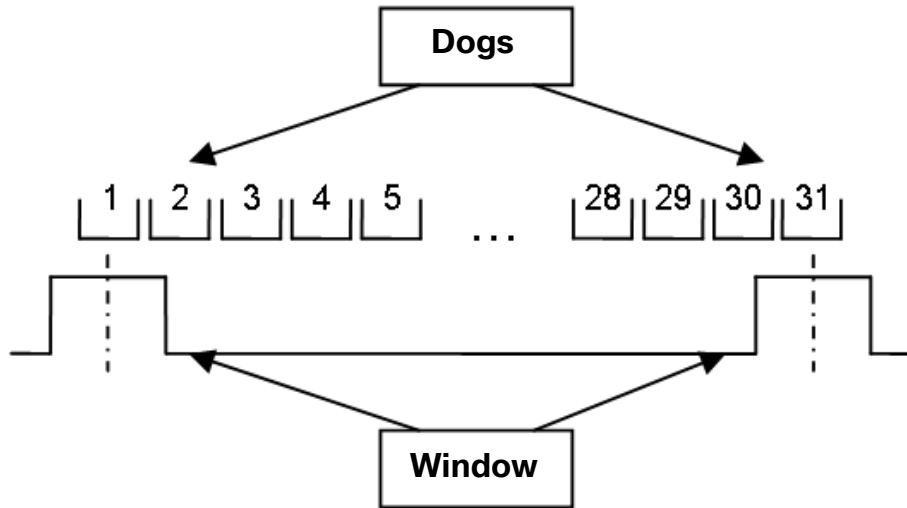

- Different simulation start positions do create different simulation results
- In order to satisfy statistical influence, a variation of initial position is necessary
- At least 30 variations should be carried out
- MATLAB-based postprocessing (Evaluation of Interval of Confidence plus Plot )

# Randomization and Parameter Variation. Shifting Comfort Evaluation.

- Representative, easy-to-understand diagram, including main simulation results
- Mainly automated postprocessing and data output throughout a large parameter variation

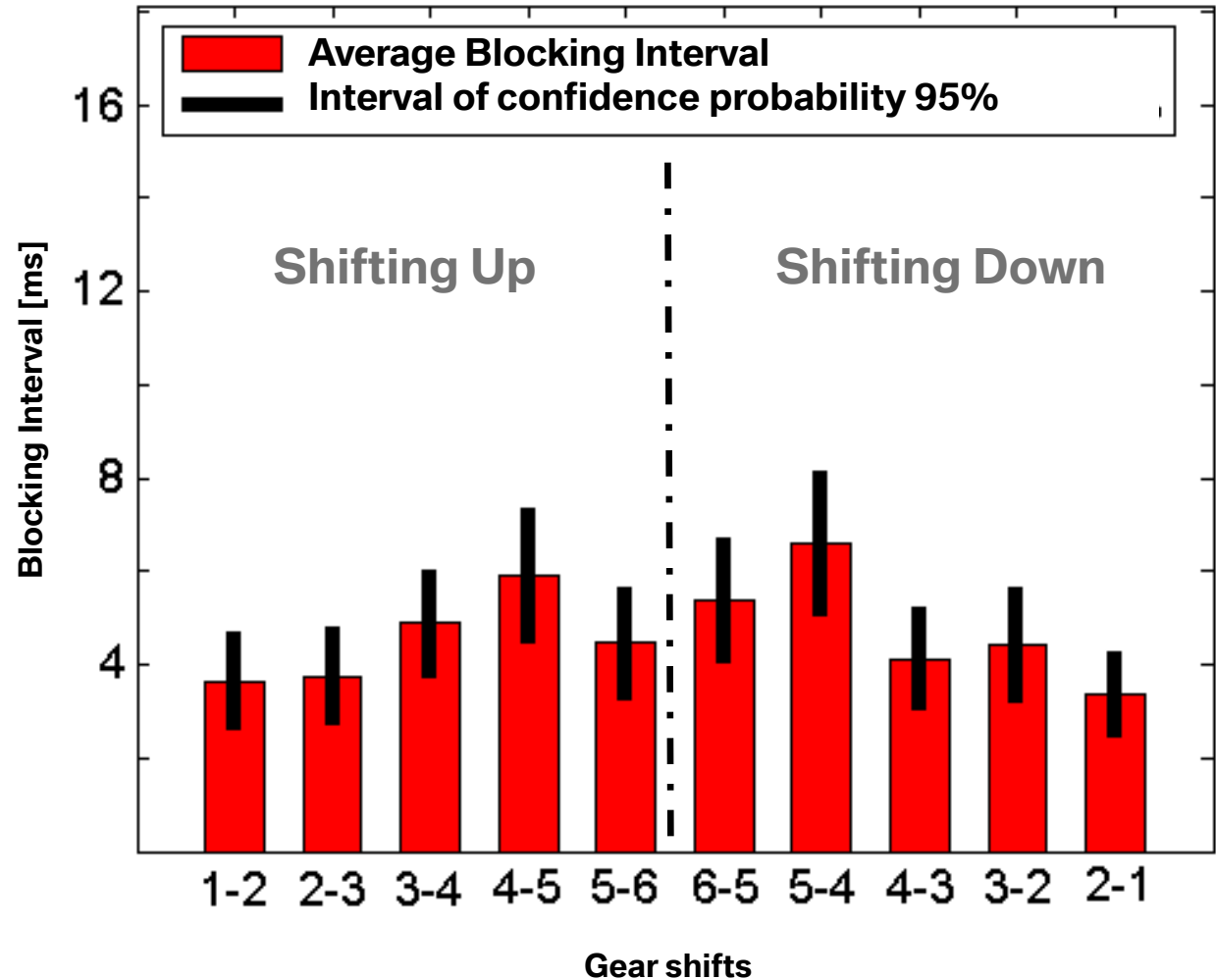

# Summary / Outlook.

- A sophisticated **method of evaluating gear shift comfort** was developed
- **Data extraction:** gear-box **torques**, component **loads** and **durability**, etc.
- Virtual **optimisation topics:** selector drum **contour variation**, component **design variations** of inner and outer shifting, **drivetrain modification**, etc.
- Extension topics: integration of **engine cyclic irregularities**, model **integration** in **vehicle model**, etc.
- Detailed analysis of **statistically distributed shifting rotational speeds** in context of shifting comfort



# Thank you very much for your attention.

User Meeting  
Salzburg  
May 2011



Freude am Fahren