

Switch Crossing Simulations

In terms of simulation, switch crossings differ in two major aspects from standard wheel-rail applications: Firstly, the rail profiles have to be modelled as a function of the track co-ordinate. Secondly, apart from the tread and the flange, an additional contact normally occurs at the back of the wheel. These two new features will be available in the new SIMPACK Wheel/Rail releases as standard features in a well tested and powerful tool to simulate switch crossings. SIMPACK Wheel/Rail is therefore able to handle one of the most problematic driving simulations of railway vehicles.

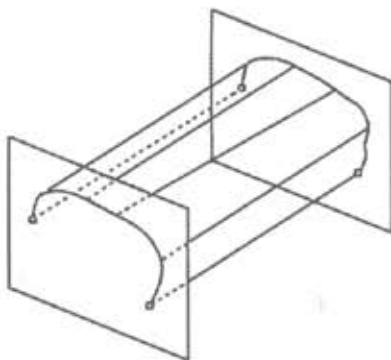
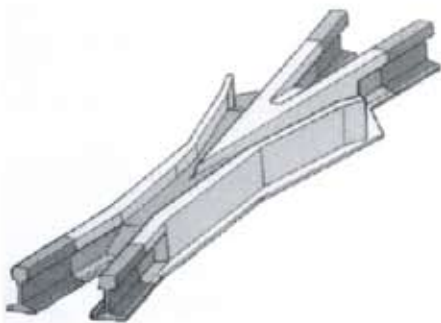

Automatic Interpolation
Between Two Measured Profiles

Changing Profiles

To define a switch crossing, rail profiles that change their shape along the course of the rail have to be available. The modelling of a switch crossing in SIMPACK Wheel/Rail is based on discrete measurements of the cross-sections of the left and right rail at certain intervals. This can lead to a quite extensive set of data to be handled. However most of the data handling is automated within SIMPACK. The ASCII files containing the cross-sectional measurements are processed within the well known and now enhanced pre-processor *Wheel/Rail Profile Approximation*. Depending on a couple of user-defined parameters, this pre-processor generates a continuous approximation of each cross section by aequi-distant parametric cubic B-splines. During simulation, a linear interpolation between the two neighbouring cross sections (described continuously now) is applied. This means that apart from providing the essential data describing the rail profiles at discrete points, the task of creating the entire rail surface along the track is carried out automatically.

Contact Conditions

Another major modelling feature needed for the simulation of railway vehicles running through a switch cross-

General Info

In SIMPACK Wheel/Rail, single as well as two-point contact can be modelled as a kinematic connection between wheel and rail. A kinematic connection uses a constraint rather than an elastic spring to model the contact forces. The elasticity of the contact patches is taken into consideration by smoothed geometry functions using a sophisticated algorithm that transfers an arbitrarily shaped contact patch into an equivalent contact ellipse. This unique method is just one of the reasons giving rise to SIMPACK's reputation of high accuracy and efficiency. For special situations, for instance wheel lift, the contact modelling can be switched from kinematic to elastic, i.e. the constraint forces are replaced by ordinary ("one side contact") springs in common with other simulation packages. However, this means that calculation times will rise.

ing is a possible contact between the backside of the wheel and the so-called check, guard or wing rail. This rail guides the wheel while running through the switch crossing. To model this additional contact a complete set of SIMPACK Wheel/Rail contact elements has to be created, consisting of markers for the profile reference frames, contact markers, contact and creep forces. Using SIMPACK, these modelling elements are created automatically for every wheelset with just a few mouse clicks.

The additional contact at the back of the wheel is modelled as an elastic contact by using spring elements for the representation of the normal forces. Spring elements as opposed to constraints are used because the contact is intermittent and the periods of contact between the back of the wheel and the rail usually are rather short. The spring element uses a one-sided spring-damper law with accurate and extensively tested parameters. The user can still edit these parameters if she or he wishes to do so.

The contact at the back of the wheel is handled independently from the main contact between tread and/or flange to ensure an efficient time integration. In the case of wheel lift, i.e. loss of contact at tread and flange, the structure of the equations of motion has to be changed. The integration is stopped internally and the kinematic contact model is replaced by the elastic model, i.e. constraints for the normal forces are removed and springs are added. The elastic contact model remains in use until the end of the simulation.

The new features in SIMPACK Wheel/Rail are accessible from the familiar

Wheel/Rail Globals window, where a vehicle model can be prepared for switch simulations with minimum effort, once the profile set-up is carried out. Defining track dependent rail profiles without the additional features for switch crossing simulations is possible as well.

Switch Simulations

The figure at the right side illustrates the general shape of a switch. Section 1 shows the unmodified stock rails before the start of the switch. At section 10 on the left rail, the switch blade takes over the contact from the tangent rail. On the right side, only the stock rail with its complete profile is modelled, as there is no contact between the back of the right wheel and the right switch blade. At position 22 contact at the back of both the left and the right wheels can occur. Around this location the wheelset is guided mainly by the right check rail. On the right hand side, the profiles of stock and check rail are fairly constant. On the left hand side however, at position 25 a second contact point on the crossing 'V' appears. Shortly after section 25 the profile of the left rail has returned to its normal dimension and there is no further contact between the wheels and the wing rail.

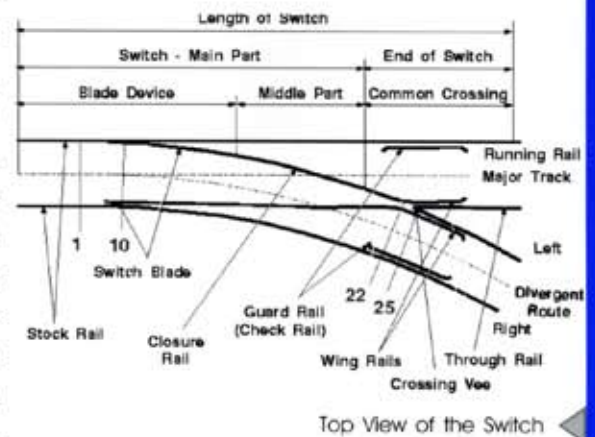

Top View of the Switch

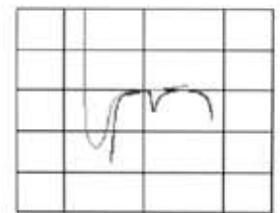

Left Profiles, Section 10

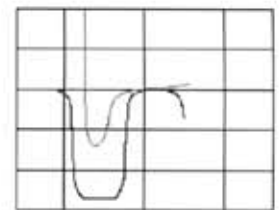

Left Profiles, Section 22

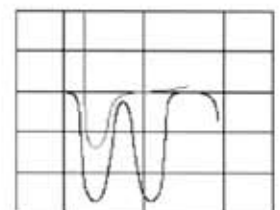

Left Profiles, Section 25