

The Customer Driven Development of SIMPACK's Durability Interface

5th SIMPACK User Meeting 2003

Stefan Dietz

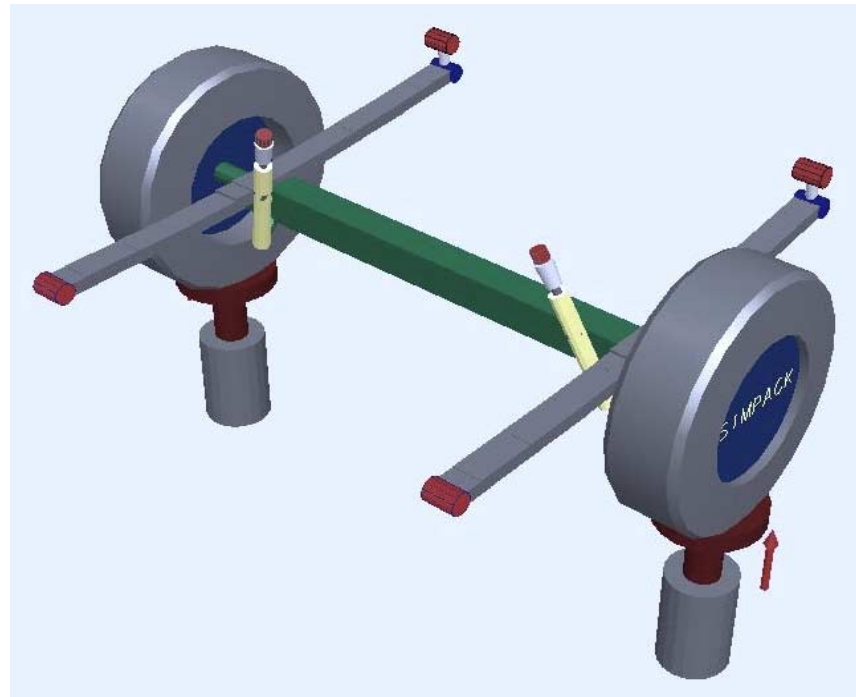

The Customer Driven Development of SIMPACK's Durability Interface

Content



Problem

Current Solutions in Comparison

The Solution Implemented in SIMPACK

Summary and Conclusion

To Do

The Customer Driven Development of SIMPACK's Durability Interface



Problem

Current Treatment of Strength Calculations

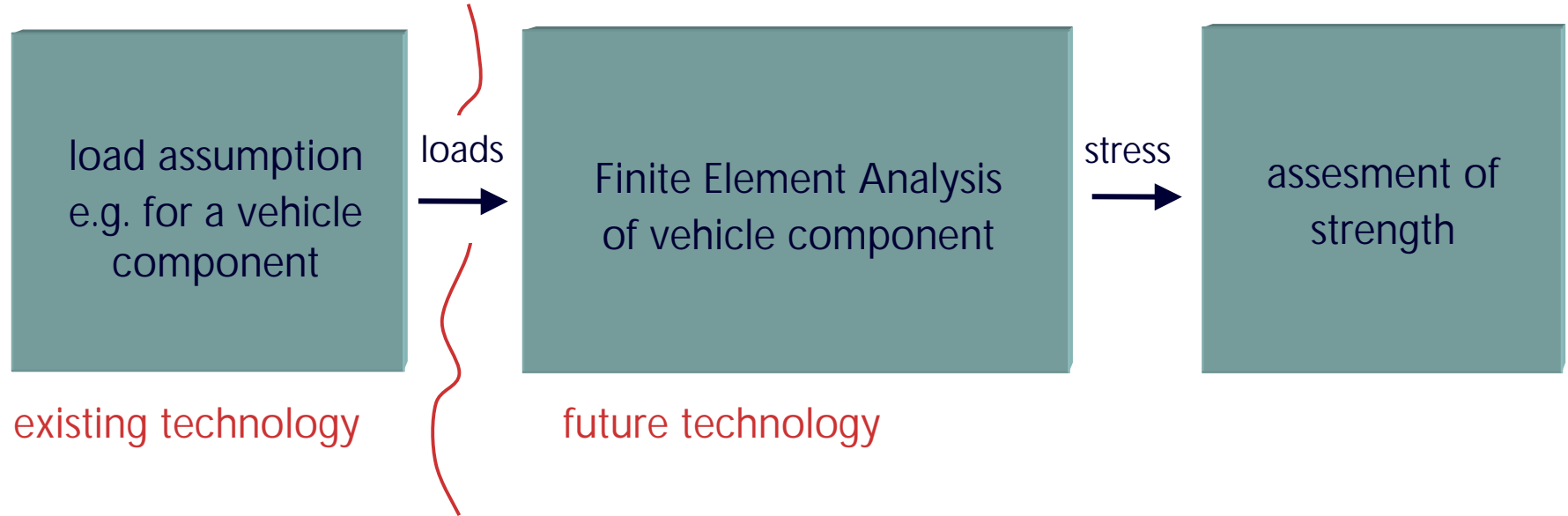

safety factor for load assumptions

conservative mechanical design

The Customer Driven Development of SIMPACK's Durability Interface



Problem

New Treatment of Strength Calculations ?

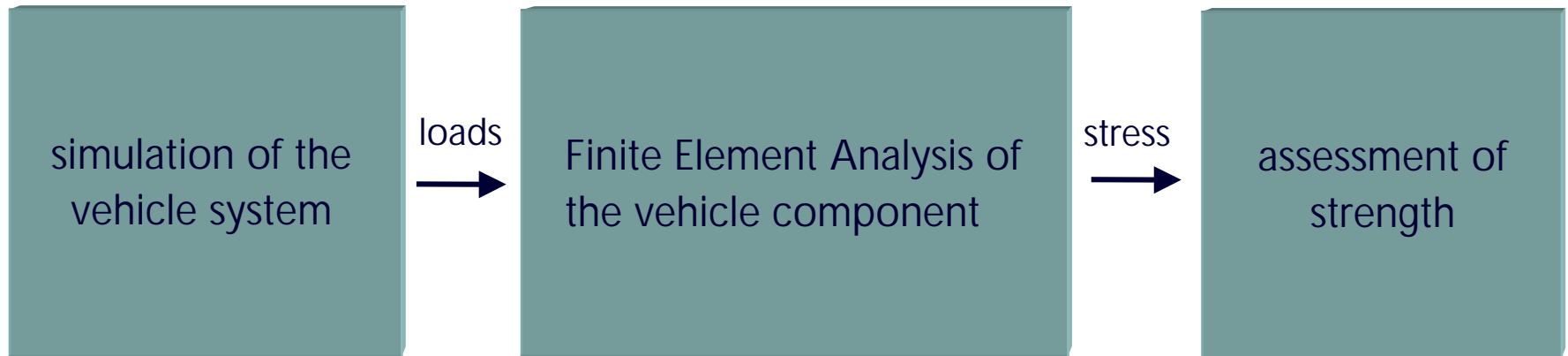

excitation of the vehicle system instead of load assumption

In the case of transient loading, finite element analysis causes high computational effort.

The Customer Driven Development of SIMPACK's Durability Interface

Current Solutions in Comparison - FE-Method



Simulating everything in a Finite Element Code ?

set-up of the simulation model

Finite Element Analysis

assessment of strength

Finite element analysis causes high computational effort for transient processes.

short-time processes

periodic load processes

The Customer Driven Development of SIMPACK's Durability Interface

Current Solutions in Comparison - Internal Force Method



Coupling FE-Codes with MBS-Codes

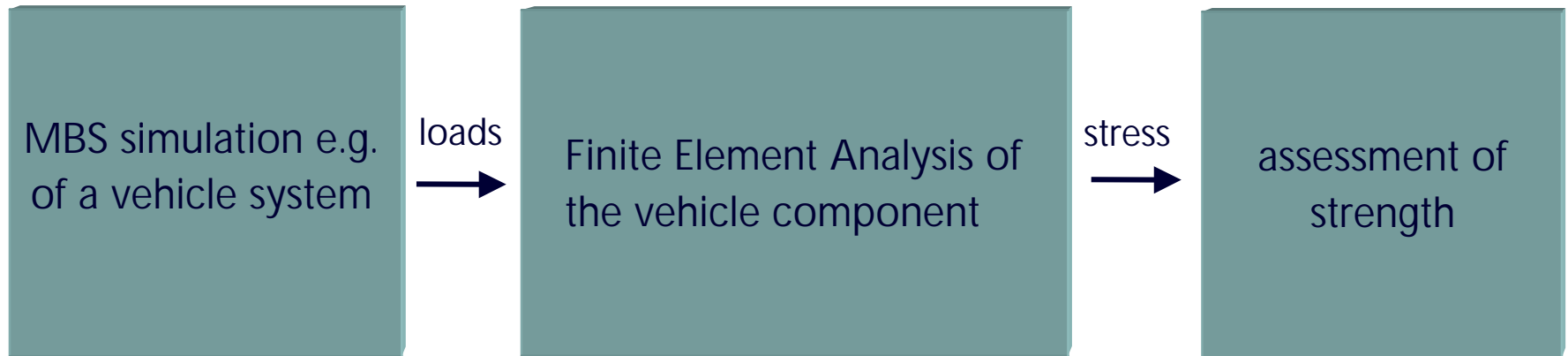

Finite element analysis causes high computational effort for transient processes.

short-time processes

periodic processes

The Customer Driven Development of SIMPACK's Durability Interface

Current Solutions in Comparison - Modal Method



Modal Stress Calculation as Post-Processing of MBS-Simulation



The Customer Driven Development of SIMPACK's Durability Interface



Current Solutions in Comparison - Modal Method

Modal Stress Calculation as Post-Processing of MBS-Calculations



The Customer Driven Development of SIMPACK's Durability Interface



Current Solutions in Comparison - Modal Method

Modal Stress Calculation as post-processing of MBS-Calculations

Stresses depend on a small number of modal co-ordinates.

no time integration in the FE-code necessary.

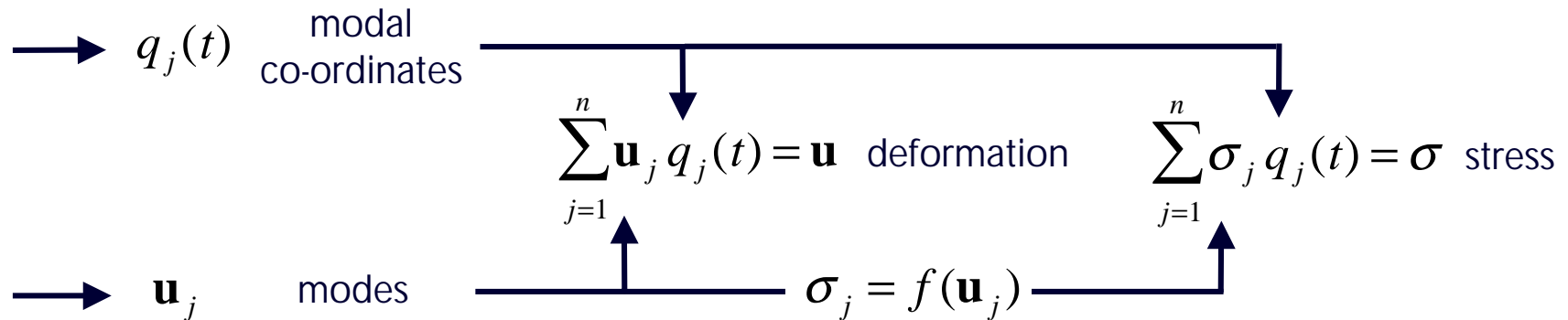

The Customer Driven Development of SIMPACK's Durability Interface

Current Solutions in Comparison - Modal Method



Modal Stress Calculation as Post-Processing of MBS-Calculations

Modal stress calculation requires for each reaction force a correction mode (static modes, frequency response modes, inertia relief modes, ...)

The majority of correction modes does not take influence on the dynamic behaviour of the MBS

Correction modes may contribute high frequencies to the MBS, slowing down the integrator

Modal stress calculations increase the number of degrees of freedom of the MBS

The Customer Driven Development of SIMPACK's Durability Interface



The Solution Implemented in SIMPACK

The Output of the MBS



→ $q_j(t)$

modal co-ordinates
describing free oscillations

→ $p_k(t)$

attachment forces
(acting in force elements, constraints and the joint)

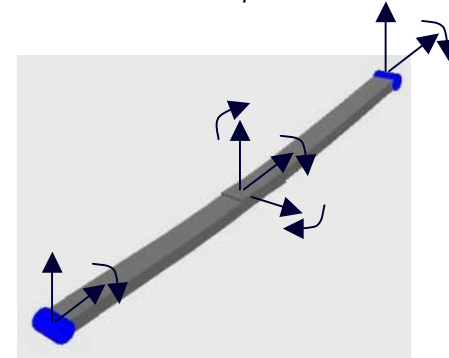

The Customer Driven Development of SIMPACK's Durability Interface



The Solution Implemented in SIMPACK

SIMPACK model
of a rear suspension

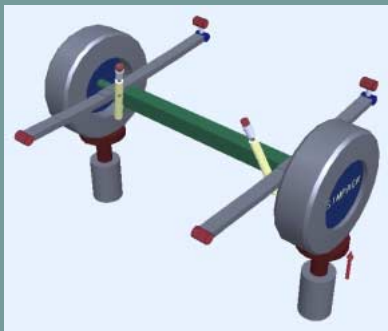

export for durability analysis
with LOADS for FEMFAT
and ANSYS

Time histories (RPCIII files):

resonance factors

internal forces (attachment forces)

channel description for FEMFAT-MAX

FEA-input files:

calculation of modal stresses for
each channel

output of ASCII files containing
modal stresses

control of calculation and output

The Customer Driven Development of SIMPACK's Durability Interface



The Solution Implemented in SIMPACK

time histories (RPCIII files):

resonance factors

internal forces (attachment forces)

channel description for FEMFAT-MAX

FEA-input files:

for the calculation of modal stresses →
for each time history

for the output of ASCII files →
containing modal stresses

to control of calculation and output →

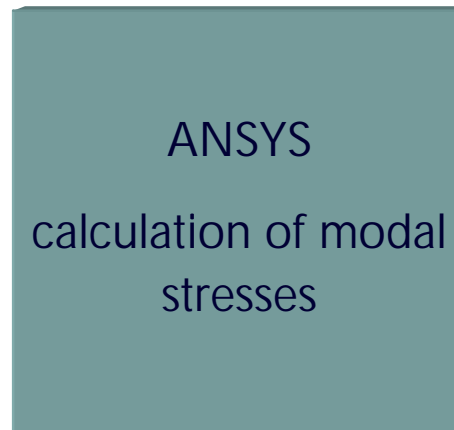

modal stresses

The Customer Driven Development of SIMPACK's Durability Interface



The Solution Implemented in SIMPACK

time histories (RPCIII files):

resonance factors

internal forces (attachment forces)

channel description for FEMFAT-MAX

modal stresses

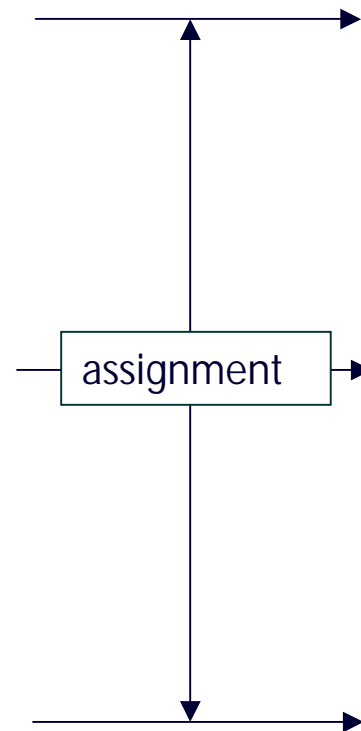

FEMFAT-MAX

read channel description

read time histories

read modal stresses

assign modal stresses
with the time histories
-> channels

superimpose channels ->
stress

assessment of strength
and durability

The Customer Driven Development of SIMPACK's Durability Interface

Summary and Conclusion



SIMPACK's durability Interface LOADS for FEMFAT enables the use of compact MBS Models.

Output of SIMPACK are time histories of attachment forces and the resonance factors describing free oscillation.

Only modes, which take influence on the dynamic behaviour of the SIMPACK model have to be considered in SIMPACK.

There is no need to consider high frequency correction modes in SIMPACK.

The interface is also applicable to rigid bodies.

The Customer Driven Development of SIMPACK's Durability Interface

To Do

improvements of the graphical user interface

faster write of time histories

use of binary format for time histories



The Customer Driven Development of SIMPACK's Durability Interface

Further Presentations About Durability on the SIMPACK User Meeting 2003



Today 14:00: Use of SIMPACK in a CAE Process Chain for Fatigue Analysis, Thomas Ille, MAN Nutzfahrzeuge AG.

